

Family Name
(Please print in BLOCK LETTERS)
as on student card

Given Name(s)
as on student card

Student Number

Practical Group
Code

UNIVERSITY OF TORONTO
Faculty of Arts and Science

APRIL 2015 EXAMINATION – version A
PHY 132H1S
Duration - 2 hours

Aids allowed: Any calculator without communication capability. Aid sheet: one single, original, handwritten 8 1/2 × 11 inch sheet of paper, which may be written on both sides. A ruler. A **paper** copy of an English translation dictionary.

- **Completely turn off** any communication device you may have and leave it with your belongings at the front of the room.
- Before starting, please **PRINT IN BLOCK LETTERS your name, student number, and practical group code** at the top of this page **and** on the answer sheet.

DO NOT separate the sheets of your question paper, except the final pages for “Rough Work” which may be removed **gently**. Your paper should have 12 pages including 3 blank sheets at the end. If this is not the case, call an invigilator.

Answer Sheet:

1. Use dark lead pencil.
2. **Locate your test version number in the header at the top of the this page, and fill in the circle with the corresponding version code on your answer sheet in the “Form Code” box.** Mark in your student number by shading the circles at the top-right of the sheet, starting with a 0 if the first digit is a 9. It is not required to bubble in your surname on the lower half of the sheet.
3. Indicate the **most correct** answer to a multiple-choice question by filling the appropriate circle on the reverse side of the answer sheet and also by circling the corresponding answer on the exam paper.
4. If you wish to modify an answer, erase your pencil mark thoroughly. Do not use whiteout.
5. **Do not write anything else on the answer sheet.** Use the back of the question sheets and either side of the blank sheets at the end for rough work.

The exam has 16 equally weighted multiple-choice questions, worth 64 marks in total, plus 4 problems, each worth 9 marks for a fully correct, worked-out solution.

Multiple-choice questions:

- Each correct answer is awarded 4 marks.
- Blank or incorrect answers are awarded zero marks.
- Multiple answers for a question are graded as a wrong answer.

Long-Answer Problem:

Maximum credit will be awarded only to fully worked solutions to all parts of the long problems. In addition to showing your work, please put your answer(s) for each part in the boxes provided. Please use the back-side of the sheets and both sides of the blank pages at the end for your rough work which will not be graded.

When the Chief Presiding Officer declares the exam ended, you must stop writing immediately. Please put your answer sheet **inside your exam paper** and have the paper ready for an invigilator to pick up.

	Marks
Part A	
Part B	
Part C	
Part D	
Total	

Good luck!

MULTIPLE CHOICE (64 marks total)

Possibly Helpful Equations and Constants

Permittivity of free space $\epsilon_0 = 8.85 \times 10^{-12} \text{ C}^2 / \text{N} \cdot \text{m}^2$

Coulomb's law constant $K = 1/(4\pi\epsilon_0) = 8.99 \times 10^9 \text{ N} \cdot \text{m}^2 / \text{C}^2$

Elementary charge (proton, electron by its magnitude) $e = 1.60 \times 10^{-19} \text{ C}$

Mass of a proton $m_p = 1.67 \times 10^{-27} \text{ kg}$, Mass of a electron $m_{el} = 9.11 \times 10^{-31} \text{ kg}$

$g = 9.80 \text{ m/s}^2$ is the acceleration due to gravity near the Earth's surface.

Random mechanics equations: $K = 1/2mv^2$, $x = x_0 + v_0t + 1/2at^2$, $v = v_0 + at$, $v^2 = v_0^2 + 2a\Delta x$

Common Prefixes: k = "kilo-" = 10^3 c = "centi-" = 10^{-2} m = "milli-" = 10^{-3}

μ = "micro-" = 10^{-6} n = "nano-" = 10^{-9}

$\pi = 3.14159$ is the ratio of the circumference to the diameter of a circle

$c = 3.00 \times 10^8 \text{ m/s}$ is the speed of light in a vacuum.

$v = 343 \text{ m/s}$ is the speed of sound in air, unless otherwise stated.

$n_{\text{water}} = 1.33$ is the index of refraction of water.

1 minute = 60 seconds; 60 minutes = 1 hour;

The quadratic equation: If $ax^2 + bx + c = 0$, then $x = \frac{-b \pm \sqrt{b^2 - 4ac}}{2a}$

Air resistance may be neglected in all questions, unless otherwise stated.

Question 1

An astronaut in an inertial reference frame measures a time interval Δt between her heartbeats. What will observers in all other inertial reference frames measure for the time interval between her heartbeats?

- (A) Δt (B) more than Δt (C) less than Δt
(D) The answer depends on whether they are moving toward her or away from her.

Question 2

A uniform rope of mass m and length L hangs from a ceiling. What is the speed of transverse waves on this rope a distance y above the lower end?

- (A) $\sqrt{\frac{mgy}{L}}$ (B) \sqrt{gy} (C) $\sqrt{\frac{m^2gy}{L^2}}$ (D) $\sqrt{\frac{mg}{L}}$ (E) \sqrt{gL}

Question 3

A closed loop conductor that forms a circle with a radius of 2.0 m is located in a uniform but time-dependent magnetic field. If the maximum emf induced in the loop is 5.0 V, what is the maximum rate at which the magnetic field strength is changing if the magnetic field is oriented perpendicular to the plane in which the loop lies?

- (A) 0.40 T/s (B) 2.5 T/s (C) 0.080 T/s (D) 5.0 T/s

Question 4

Two in-phase loudspeakers are some distance apart. They emit a low “C”-note in all directions with a frequency of 65.4 Hz. You move between the speakers, along the line joining them, at a constant speed of 3.50 m/s. As you do so, the intensity of the combined sound you hear rises and falls in periodic “beats”. What is the period of these beats?

- (A) 0.667 s (B) 0.749 s (C) 1.33 s (D) 1.50 s (E) 131 s

Question 5

A circular loop of wire is positioned half in and half out of a square region of constant uniform magnetic field directed into the page, as shown on the right. To induce a counterclockwise current in this loop:

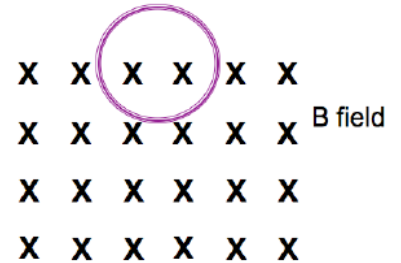

- (A) move it slightly to the right.
(B) move it slightly to the left.
(C) move it up toward the top of the page.
(D) move it down toward the bottom of the page.
(E) increase the strength of the magnetic field.

Question 6

A piano tuner stretches a steel piano wire with a tension of 1200 N. The steel wire has a length of 0.600 m and a mass of 4.50 g. What is the mode number m of the highest harmonic that could be heard by a person who is capable of hearing frequencies up to $f = 14$ kHz?

- (A) 5 (B) 21 (C) 42 (D) 60 (E) No harmonic could be heard by this person.

Question 7

A negatively charged particle is moving to the right, directly above a wire having a current flowing to the right, as shown in the figure. In which direction is the magnetic force exerted on the particle?

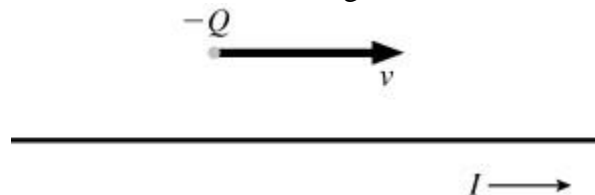

- (A) into the page (B) out of the page (C) downward (D) upward
(E) The magnetic force is zero since the velocity is parallel to the current.

Question 8

Light of a single wavelength, λ , is shone onto a single narrow slit of width a . The diffraction pattern formed on a distant screen has its first minimum at an angle of 30° with respect to the central maximum. What is the ratio a/λ ?

- (A) 0.50 (B) 0.83 (C) 1.15 (D) 1.6 (E) 2.0

Question 9

We have a parallel-plate capacitor with a separation distance of 1.00 mm and plate area of $5.00 \times 10^{-2} \text{ m}^2$. Each plate carries a charge of magnitude $3.00 \mu\text{C}$ and of sign opposite to the other plate. What is the approximate magnitude of the electric field in the middle of the capacitor?

- (A) $1.69 \times 10^4 \text{ N/C}$ (B) $6.78 \times 10^6 \text{ N/C}$ (C) $5.90 \times 10^2 \text{ N/C}$
(D) $1.48 \times 10^{-4} \text{ N/C}$ (E) $5.32 \times 10^5 \text{ N/C}$

Question 10

Four equally charged particles with charge q are placed at the corners of a square with side length L , as shown. A fifth charged particle with charge Q is placed at the centre of the square so that the entire system of charges is in static equilibrium. What is the charge Q ?

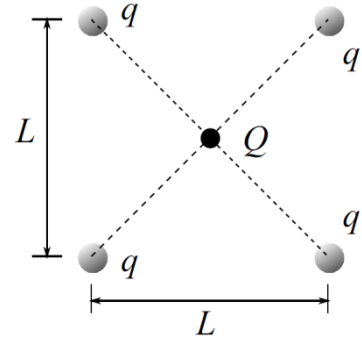

- (A) $-q(2 + 2\sqrt{2})$ (B) $-q(1 + \sqrt{2})$
(C) $-q\left(\frac{1+2\sqrt{2}}{2}\right)$ (D) $-q\left(\frac{1+2\sqrt{2}}{4}\right)$
(E) $-q\left(\frac{1}{\sqrt{2}}\right)$

Question 11

A flat square is 3 meters on each side. The square is oriented as seen in the picture. The plane of the square is perpendicular to the page. What is the magnitude of the magnetic flux going through the square?

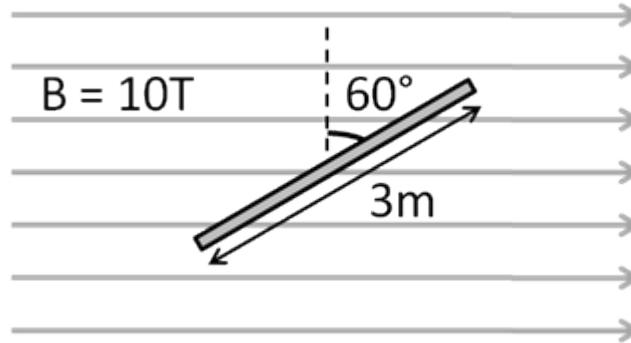

- (A) 12.1 Tm^2 (B) 30 Tm^2 (C) 45 Tm^2 (D) 78 Tm^2 (E) 90 Tm^2

Question 12

An electron is initially moving to the right when it enters a uniform electric field directed upwards. Which trajectory shown below will the electron follow?

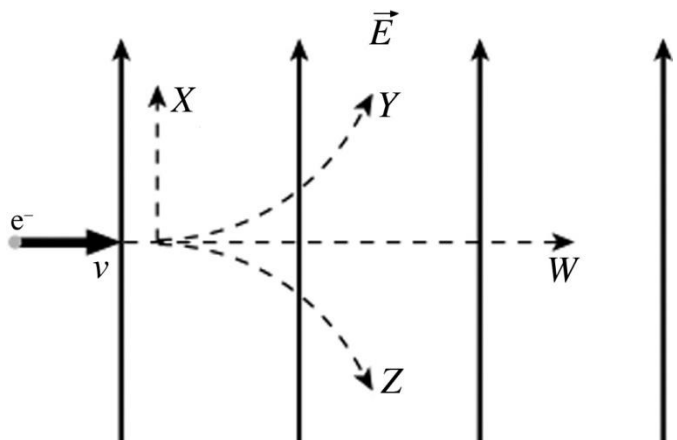

- (A) trajectory W
(B) trajectory X
(C) trajectory Y
(D) trajectory Z

Question 13

A positively charged particle is injected into a region occupied by a uniform magnetic field B pointing out of the paper. The particle's initial velocity, v_0 , is straight upward. It emerges from the B field region at position X , after travelling for a time Δt through the field. If the particle was injected instead with velocity $2v_0$, it would

- (A) emerge at the same position X , but after an amount of time different than Δt .
- (B) emerge at a position different than X , but after the same amount of time Δt .
- (C) emerge at a position different than X and after an amount of time different than Δt .

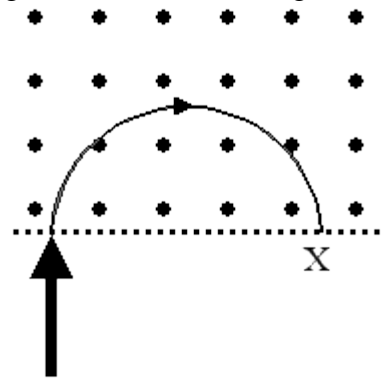

Question 14

An electric dipole is centered at the origin and oriented along the x -axis with the positive charge located to the right of the origin. The dipole consists of two particles of charge magnitude $2.0 \mu\text{C}$, separated by 0.10 cm . What is the electric field due to this dipole at the point $x = +4.0 \text{ m}$, $y = 0.0 \text{ m}$?

- (A) $-0.56 \hat{i} \text{ N/C}$
- (B) $-0.28 \hat{i} \text{ N/C}$
- (C) $0.28 \hat{i} \text{ N/C}$
- (D) $0.56 \hat{i} \text{ N/C}$
- (E) zero

Question 15

A dielectric with dielectric constant $\kappa > 1$ can be inserted into a capacitor in two different ways as follows:

- i) The capacitor is charged from a battery, disconnected, and then the dielectric is inserted so that it fills all the space between the plates.
- ii) The capacitor remains connected to the same battery while the dielectric is inserted so that it fills all the space between the plates.

After the dielectric is inserted in both cases:

- (A) The energy stored in the capacitor in case i) is larger than the energy stored in the capacitor in case ii).
- (B) The energy stored in the capacitor in case i) is smaller than the energy stored in the capacitor in case ii).
- (C) The energy stored in the capacitor is the same for both cases.

Question 16

A parallel-plate capacitor has plates of area A . The plates are separated by a distance d which is much smaller than the dimensions of the plates. When the capacitor is connected to a battery, the energy density within the capacitor is u . If you can only change the distance between the plates, with all other properties of the system being the same, at what distance would the capacitor have an energy density of $4u$?

- (A) $d/4$
- (B) $d/2$
- (C) $2d$
- (D) $4d$
- (E) $16d$

LONG ANSWER PROBLEM (36 marks total)

Clearly show your reasoning as some part marks may be awarded. Write your final answers in the provided boxes.

PART A [9 marks]

Two batteries are arranged in a circuit with two resistors as shown in the figure. The resistance of each resistor is not given, but the indicated currents are observed to flow through the two resistors. Assume all wires and batteries are ideal and that the resistors are perfectly ohmic.

i) Find the power delivered by each battery $P_{20\text{ v}}$ and $P_{30\text{ v}}$.

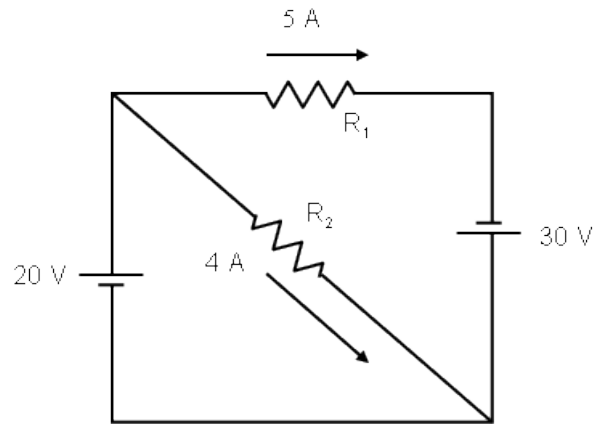

$P_{20\text{ v}} =$
$P_{30\text{ v}} =$

ii) Find the resistances R_1 and R_2 .

$R_1 =$
$R_2 =$

PART B [9 marks]

An electron ($q = -1.6 \times 10^{-19}$ C) travelling horizontally at speed $v = 3 \times 10^4$ m/s enters a region of uniform magnetic field $B = 0.2$ T directed into the page, as shown. What is the direction, and magnitude, of the electric field E needed so that the electron travels in a straight line? (Neglect gravity.)

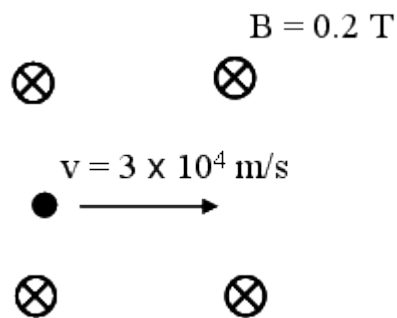

$\vec{E} =$

PART C [9 marks]

Shown from above in the figure is one corner of a rectangular box filled with water. A laser beam starts 10.0 cm from side A of the container and enters the water at position x . You can ignore the thin transparent walls of the container. What is the minimum value of x for which the laser beam passes through side B and emerges into the air?

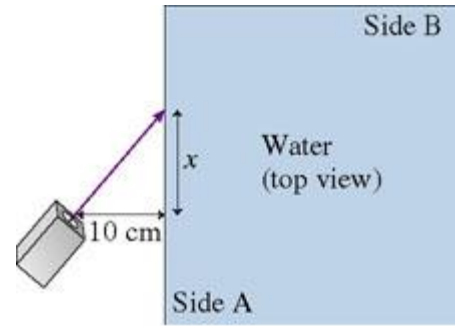

$x =$

PART D [9 marks]

An electron and a proton are held in fixed positions on the x -axis, with the electron at $x = +1.00$ m and the proton at $x = -1.00$ m. A second electron is initially at $x = +20.00$ m on the axis, and is given an initial velocity of 50 m/s toward the origin.

- (i) **[4 marks]** Will the moving electron reach the origin? [Circle the letter of choice A or B.]
A. Yes, the moving electron will reach the origin.
B. No, the moving electron will stop before reaching the origin.
- (ii) **[5 marks]** If you answered A to part (i), compute the speed of the moving electron when it reaches the origin. If you answered B to part (i), compute the distance of the electron from the origin at the moment when it stops.

ROUGH WORK (not marked)

ROUGH WORK (not marked)

ROUGH WORK (not marked)