

USER'S GUIDE

6000 Vortex™ Series

Tunable Diode Laser

*U.S. Patents #5,319,668 & #5,995,521 and
European Patent #0 693 231 B1*



CAUTION!

*Use of controls or adjustments, or performance of procedures
other than those specified herein, may result in hazardous
radiation exposure.*



NEW FOCUS®

5215 Hellyer Ave. • San Jose, CA 95138-1001 • USA
phone: (408) 284-6808 • fax: (408) 284-4824
e-mail: contact@newfocus.com • www.newfocus.com

Warranty

New Focus, Inc. guarantees its Vortex lasers to be free of material and workmanship defects for one year from the date of shipment or 3,000 hours of operation, whichever comes first. This warranty is in lieu of all other guarantees expressed or implied and does not cover incidental or consequential loss.

Please note that each Vortex laser is custom built to the user's exact wavelength specification. Because of the custom nature of this product, returns are accepted only within 30 days from the date of purchase and are subject to a restocking fee of 50% of the original cost.

Products described in this document are covered by U.S. Patents #5,319,668 and #5,995,521 and European Patent #0 693 231 B1.

Information in this document is subject to change without notice.
Copyright 2002, 2001–1998, New Focus, Inc. All rights reserved.

The  NEW FOCUS[®] and  NEW FOCUS[®] logos, and NEW FOCUS, Inc. are registered trademarks and Vortex is a trademark of NEW FOCUS, Inc. Littelfuse and Slo-Blo are registered trademarks of Littelfuse, Inc.

Contents

User Safety	5
Introduction	5
Laser Safety	5
Using the Safety Interlock	7
Getting Started	9
Introduction	9
Unpacking the System.....	9
Setting Up the Laser	10
Starting the Vortex for the First Time	11
General Operation	13
Overview	13
What's Inside	13
Mounting the Laser Head	14
Using the Front-Panel Controls	15
Turning on the Power	17
Selecting an Operating Mode	17
Displaying and Setting the Laser Parameters	19
Restoring Local (Front-Panel) Control	20
Modulating the Laser Output	20
Reading an Input Signal	23

Constant-Power Mode	25
Introduction	25
Preparing to Use Constant-Power Mode	25
Operating in Constant-Power Mode.....	26
Computer Control	29
Introduction	29
Using the IEEE-488 Interface	29
Using the RS-232 Interface.....	30
Restoring Local (Front-Panel) Control	31
Understanding the Command Types	31
Conventions	31
Command Summary	34
Command Definitions.....	36
Principles of Operation	49
Overview	49
General Theory	49
Changing the AC-Voltage Selection	53
Customer Service	55
Service.....	55
Technical Support.....	55
Appendix I: Physical Specifications	57
Controller	57
Laser Head and Mounting Bracket.....	58
Appendix II: RS-232 Connector Wiring	59
Index	61

User Safety

Introduction

Your safe and effective use of this product is of utmost importance to us at New Focus. Please read the following laser safety information before attempting to operate the laser.

Laser Safety

The laser radiation emitted from this unit may be harmful. Always follow these precautions:

- Avoid direct exposure to the beam.
- Avoid looking at the beam directly.
- Be aware of and follow the warnings on the safety labels (examples are shown on page 6).
- To completely shut off power to the unit, turn off the keyswitch. The **Power** button on the front of the controller controls power to the laser diode; even when the power to the diode is off, power is still being supplied to the laser head for temperature control.
- Do not open the laser head or controller.



Diode-laser power at the wavelengths shown in the following table could be accessible inside the laser head. There are no user-serviceable parts inside the laser head or controller. Unauthorized opening of the head or controller will void the warranty and may result in misalignment of the laser cavity and/or irreparable damage to the internal components.

The following table contains a list of wavelength ranges and maximum internal powers accessible inside the different model laser heads. Look at the label on top of your laser head for its model number and its specific wavelength.

Model	Wavelength Range	Max. Power
6003	350–500 nm	10 mW
6005	600–645 nm	15 mW
6009	630–710 nm	30 mW
6013	710–800 nm	70 mW
6017	760–905 nm	100 mW
6021	830–1180 nm	100 mW
6025	1100–1480 nm	30 mW
6027	1350–1650 nm	50 mW
6029, 6029-Power	1380–1710 nm	50 mW
6031	1550–1900 nm	25 mW
6033	1610–2400 nm	100 mW



The actual output power and wavelength range of your laser will only be a fraction of the internal diode power and wavelength range shown here.

Label Identification

The aperture and danger labels shown here pertain to different wavelength laser heads. Depending on your specific wavelength requirements, other labels similar to those shown may be used.

Figure 1:
Labels on the front and top of the laser head

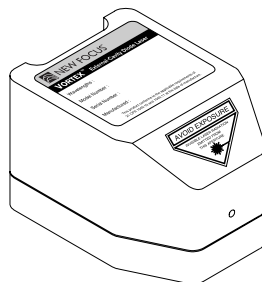

Front of laser head



Aperture labels

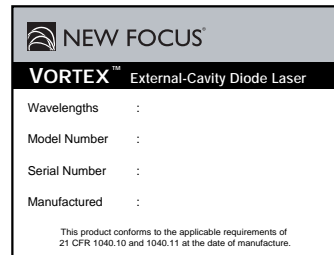

Certification label

Figure 2:
Labels on the back
of the laser head

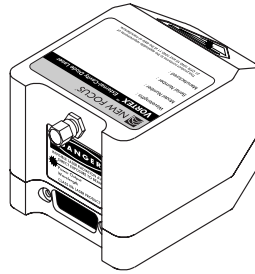

Back of laser head

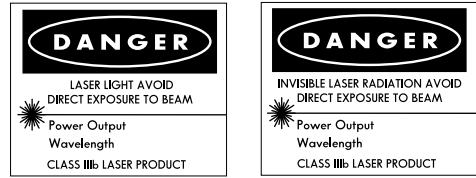

Danger labels

Using the Safety Interlock

The safety interlock connector on the back of the Vortex controller is provided for external safety systems. The system is shipped with a jumper across the interlock terminals. Do not remove this jumper unless you are using the safety interlock feature; the laser will not emit light unless the interlock circuit is closed. The circuit carries 15-V DC.

Getting Started

Introduction

This section outlines the basic steps needed to start using your Vortex laser system, including information on unpacking the system and brief set-up and starting notes. For more detailed information on how to operate the instrument, refer to the “General Operation” chapter beginning on page 13.

Unpacking the System

Carefully unpack the Vortex laser system. Compare the contents against the packing slip and inspect them for any signs of damage. If parts are missing or you notice any signs of damage, such as dented or scratched covers, or broken knobs, please contact New Focus immediately.



For orders with multiple heads, up to 3 heads may be shipped in the same container.

Save the shipping container and packing material for future shipping needs.

Check that the power module on the back of the controller is set for the proper AC line voltage (see page 53 for information on checking and changing the voltage).

Setting Up the Laser

1. **Mount the laser head:** The laser head is shipped with a mounting bracket already attached. This bracket also serves as a heatsink to avoid overheating the laser head. Mount the laser head/bracket in a stable position with the output aperture pointing towards an appropriate beam block. Output-beam height is two inches. See page 14 for details on mounting techniques.
2. **Position the controller:** Position the controller within a cable length of the laser head (about five feet). Make sure that the side and rear vents of the controller are not blocked. The controller keyswitch should be off (position “0”).
3. **Connect the head and controller:** Connect the controller to the laser head with the 26-pin D-connector laser cable provided. Use only the supplied New Focus laser cable to connect the controller to the laser head. To ensure proper and safe operation of the laser, secure the cable to the laser head and controller using the captive attachment screws in the cable’s D-connectors.

Figure 3:
Controller to Laser
Head Connection

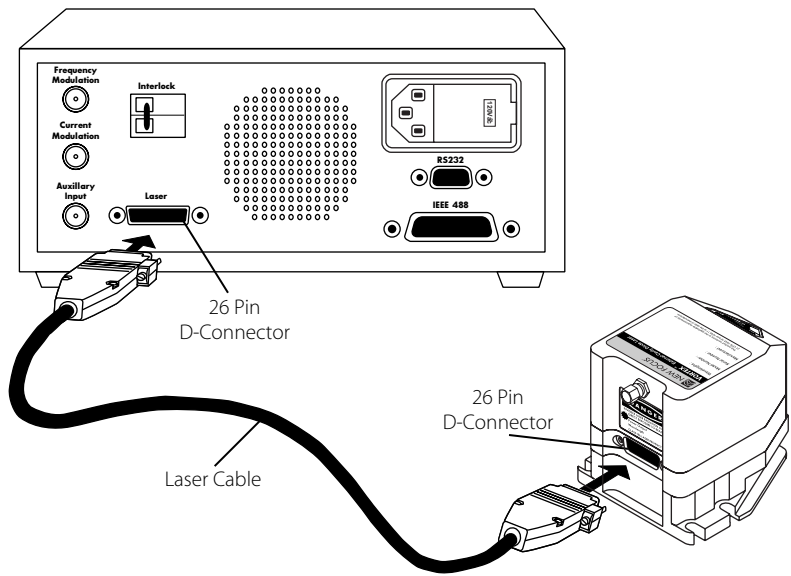

4. **Connect the power cord:** Attach the power cord to the controller and plug it into a wall outlet.

Note:

This instrument is configured at the factory for the line voltage and frequency appropriate for your country. If you are unsure of how your unit is configured, see “Changing the AC-Voltage Selection” on page 53.

5. **Optically isolate the laser:** Take precautions to prevent back reflections into the laser head. Isolation can be achieved by angling your optics or with the use of an optical isolator. The degree of isolation required depends on how you are using the laser; contact New Focus technical support for help with your particular application.

Starting the Vortex for the First Time

The following section takes you through the basic steps of starting up and shutting down the laser. The controls and functions are described in more detail in the following chapter.

Figure 4:
Vortex Front Panel

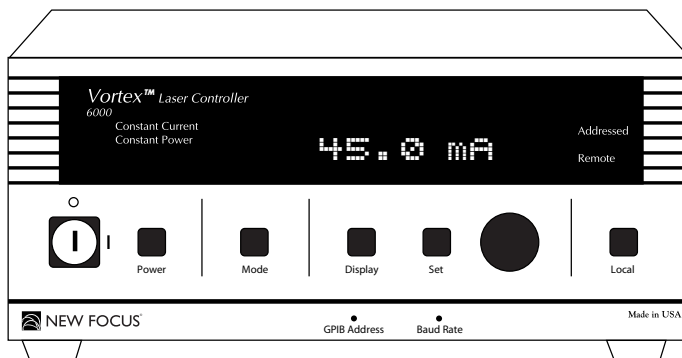

1. **Turn on the system:** Turn the keyswitch to “ON” (position “|”). The system will start up in constant-current mode with the current set to 0 mA, and the system ID will scroll across the display.

Note:

After turning the keyswitch, allow the system a minimum of 20 minutes to reach a stable temperature before turning on the laser diode (step 4).

Once the keyswitch is turned on, the system can be operated remotely through the IEEE-488 (GPIB) or RS-232 ports. Refer to the “Computer Control” chapter beginning on page 29 for details.

- 2. Set the operating mode:** An LED on the front panel will indicate the system's operating mode: constant-current or constant-power. To change modes, press the **Mode** button.

You will need to use an external photodetector to operate the Vortex in constant-power mode. See “Selecting an Operating Mode” on page 17 for details on the different modes, or the “Constant-Power Mode” chapter beginning on page 25 for details on setting up and using the laser in constant-power mode.

- 3. Set the operating current or power:** Press the **Display** button until the current, “0.0 mA” (for constant-current mode), or the power, “0.0%” (for constant-power mode), is displayed. If the **Set** button is not already lit, press it to enable the adjustment knob. Turn the knob to set the current or power.



To prevent damage to the laser diode, the factory has limited the maximum current to the operating current listed on the Acceptance Test Data Sheet.

- 4. Activate the laser:** Push the **Power** button to activate the laser power. The button will flash for 5 seconds before current flows through the diode.

Laser light should now be emitting from the aperture.



Laser radiation emitted from this unit may be harmful. Avoid direct exposure to the beam.

- 5. Turn the laser off:** To minimize the risk of power surges damaging the laser diode, push the **Power** button to turn off the laser when it is not in use (the LED on the button will turn off) and before shutting down the system. Turn the keyswitch off (position “0”) to shut down the entire system.

General Operation

Overview

The Vortex is a robust, narrow-linewidth, laser source. The system consists of a laser controller, a laser head, and a laser cable. Each Vortex laser head contains head-specific information so that it can be used with any Vortex laser controller. This modular design allows you to switch wavelengths simply by changing the laser head (heads are available separately). The system can be operated manually, using the front-panel controls, or remotely, using one of the computer interfaces.

What's Inside

The Vortex laser is an external-cavity diode laser (ECDL) based on the Littman-Metcalf design (see “Principles of Operation” on page 49). The customer-selected wavelength is set and stabilized at the factory using external optics, a diffraction grating, a mirror, and precision temperature control. Fine wavelength tuning without mode hops is achieved by rotating the mirror around a fixed rotation point using a piezoelectric actuator. Laser output power is controlled by an ultra-low-noise current source.

The controller contains the electronics for laser-current, laser-temperature, and piezo-voltage control, as well as digital-interface electronics. A dimensional drawing of the controller is located in “Appendix I: Physical Specifications” on page 57. The temperature of the laser cavity is set at the factory for optimum laser performance and is not adjustable by the user, although you can read the temperature using the computer interface (see “Computer Control” on page 29). The

laser current controls the optical output power. The piezo voltage controls the laser wavelength (frequency). Both of these parameters can be adjusted through the front-panel controls, the computer interface, or the back-panel BNC connectors.

Mounting the Laser Head

Proper mounting of the laser head is essential for stable wavelength operation. The output wavelength is strongly dependent on the temperature of the laser cavity, which is actively stabilized using a thermoelectric cooler (TEC). The TEC utilizes the laser-head housing as a heat reservoir. For this reason, the mount for the laser head needs to provide a good thermal path away from the laser head. The mounting bracket included with each laser head provides such a path when it is in contact with a large thermal mass, such as an optical table.

The laser head can be mounted with or without the enclosed mounting bracket (shipped attached to the laser head). Dimensional drawings of the laser head and the mounting bracket are shown in Appendix I on page 58. The mounting bracket is designed for use with metric (25-mm spacing, M6) or English (one-inch spacing, 1/4-20) breadboards. If you are mounting the laser head without the included mounting bracket, take steps to ensure it has an adequate thermal heat sink.

Setting the Beam Height

The laser beam height is one inch (25.4 mm) from the bottom of the laser head. The mounting bracket adds one additional inch (25.4 mm) to the beam height. To raise the beam height, additional risers are available from New Focus (model number 6001).

Optically Isolating the Laser

After mounting the laser head, take precautions to prevent back reflections into the laser aperture. Isolation can be achieved by angling your optics or with the use of an optical isolator. The degree of isolation required depends on how you are using the laser; contact New Focus technical support for help with your particular application.

Using the Front-Panel Controls

The Vortex has two control options, local and remote. In local mode, the front panel provides control of the laser system. In remote mode, you control the laser over the computer interface (IEEE-488 or RS-232). Whenever the Vortex receives a command over the computer interface, it automatically deactivates most of the front-panel controls (the **Local** button, which restores local control, and the **Power** button and power keyswitch all remain active). For information on using computer control, see page 29.

The controls on the front panel (Figure 5) allow you to switch system operating modes and to read and set the laser current, laser power, piezo voltage (which controls the laser wavelength), and computer-interface parameters.

Figure 5:
Controller front panel

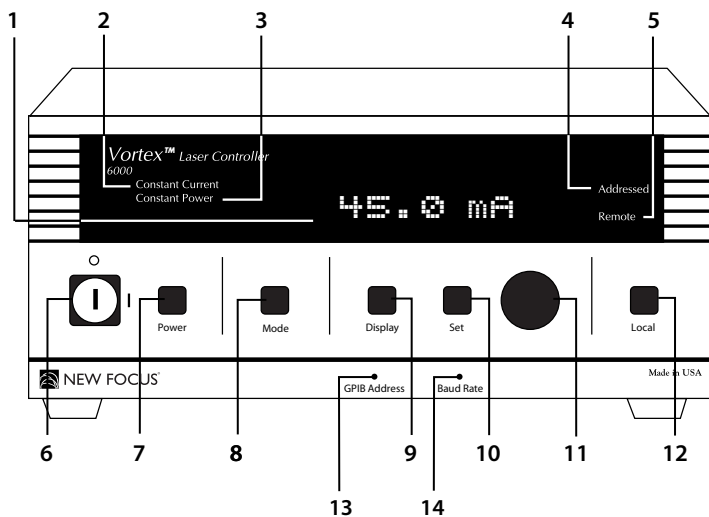

1. **Display:** The display shows the various laser parameters, as well as errors and system-identification information.
2. **Constant Current Indicator:** This indicator is lit when the laser is set for constant-current mode.
3. **Constant Power Indicator:** This indicator is lit when the laser is set for constant-power mode.

4. **Addressed Indicator:** This indicator is lit whenever the controller is communicating over the computer interface (see the “Computer Control” chapter beginning on page 29).
5. **Remote Indicator:** This indicator is lit whenever the controller is under computer control, via either the IEEE-488 (GPIB) or the RS-232 interface. (See “Computer Control” on page 29.)
6. **Power Keyswitch:** Controls AC power to the entire laser system, including the temperature circuit in the laser head.
7. **Power Button:** Turns on and off current to the laser diode.
8. **Mode Button:** Switches the laser between constant-current and constant-power modes (power to the laser diode must be off to switch modes).

Constant-power mode requires an external beamsplitter and photodetector. See the “Constant-Power Mode” chapter beginning on page 25 for details.
9. **Display Button:** Changes the display to show laser current, laser power, piezo voltage, or auxiliary input voltage.
10. **Set Button:** Activates/de-activates the adjustment knob so you can adjust the displayed laser parameter (the properties you can control depend on the operating mode).
11. **Adjustment Knob:** When activated by the **Set** button, this knob is used for all adjustments of laser and system parameters.
12. **Local Button:** Returns the controller to local (front-panel) control when the driver is in remote (computer) control.
13. **GPIB Address Button:** Displays the GPIB (IEEE) address setting. See “Using the IEEE-488 Interface” on page 29 for more information.
14. **Baud Rate Button:** Displays the RS-232 baud-rate setting. See “Using the RS-232 Interface” on page 30 for more information.

Turning on the Power

Before turning on the system for the first time, check that the AC line voltage indicator on the back of the controller matches the voltage you are using (see page 53).

To turn on the Vortex:

1. Turn the power keyswitch on the front panel clockwise (to the “|” position).
This turns on AC power for the entire laser system, including the temperature circuit in the laser head.
2. Wait at least 20 minutes after turning on the keyswitch to allow the laser head to reach a stable temperature.
3. Press the **Power** button on the controller front panel to allow current to flow to the laser head. The button will flash during the five-second safety delay before the current is activated. The button will remain lit while current is flowing to the laser diode.



The diode will not emit laser light until the current is set high enough to meet the threshold current.

Before turning off the system, you should first turn off power to the laser diode by pressing the **Power** button.

Selecting an Operating Mode

The Vortex laser-current driver operates in either constant-current mode or constant-power mode. Constant-current mode results in narrower laser linewidth while constant-power mode results in the lowest intensity fluctuations. The constant-current or constant-power indicator on the controller display will indicate the active mode.

Constant-Current Mode

When operating in constant-current mode, the controller maintains a stable set current with the low-noise current driver. This results in a narrow laser linewidth.

While in constant-current mode, you can adjust the diode current and laser wavelength (piezo voltage). To change one of these parameters from the front panel, display the current (mA) or piezo voltage (V), press the **Set** button so it is lit, and turn the adjustment knob. The laser power is not adjustable in this mode; the power is read from the back facet of the laser diode, and is only accurate to within about 20% of the true laser output power.

Each laser head is designed and built for a specific operating current and has a factory-limited maximum current level to prevent possible damage to the laser diode. This current limit also limits the maximum power output from the laser head.

Constant-Power Mode

When operating in constant-power mode, the controller adjusts the laser current to maintain a stable output power. Only power and laser frequency (piezo voltage) can be varied in constant-power mode. The laser power displayed in this mode is given in terms of a percentage of maximum auxiliary input signal.

Constant-power mode requires use of an external beamsplitter and a photodetector to measure the laser power and provide an electrical signal for the internal feedback circuit.

See the “Constant-Power Mode” chapter beginning on page 25 for details on setting up and using the Vortex in constant-power mode.

Setting the Operating Mode

The Constant Current and Constant Power LEDs on the front panel (see Figure 5 on page 15) indicate which mode is active.

To change the mode:

1. Make sure the power to the laser head is off.
If the LED in the **Power** button is lit, then the laser head is on: press the **Power** button to turn off the laser power.
2. Press the **Mode** button to switch modes. The mode indicator on the front panel will change to show the newly selected mode.

3. Press the **Power** button to re-activate the laser head.

In order to use the Vortex in constant-power mode, you will need to use a beamsplitter and a photodetector (see “Constant-Power Mode” on page 25 for details).

Displaying and Setting the Laser Parameters

Use the front panel to display either the set value or the actual operating value of the laser parameter you want: current, laser power, piezo voltage (which controls wavelength), or auxiliary input voltage. The operating mode (constant-current or constant-power) determines which parameters you can adjust.

1. Press the **Display** button to view the parameter you want. The units on the display indicate which parameter is active:
 - Laser current is displayed as “x.x mA.”
 - Laser power is displayed as “x.x mW” in constant-current mode and as “x.x%” when in constant-power mode. In constant-current mode, the power is read from the back of the laser-diode, and is therefore only accurate to approximately 20% of the true laser output power.
 - Piezo voltage is displayed as “x.x V.” This is a direct readout of voltage to the piezoelectric actuator that controls the wavelength. Increasing the voltage decreases the wavelength (increases the frequency). The voltage range is 0–117.5 V.
 - Auxiliary input is displayed as “aux x.xx” (not adjustable).
2. Switch the **Set** button on or off, depending on the value you want to see. If the LED in the **Set** button is lit, then the display will show the set value of the parameter; if the LED is not lit, then the display will show the operating value.

If the LED does not go on, then you cannot adjust the displayed value. For example, in constant-current mode you can’t adjust the power and in constant-power mode you can’t adjust the current.
3. To adjust the set value for the parameter, enable the **Set** button and turn the adjustment knob.

Turn the knob clockwise to increase the value, counter-clockwise to decrease the value. The knob has a built-in acceleration feature: to make large changes, turn the knob quickly.

Restoring Local (Front-Panel) Control

When the Vortex receives a command from the computer interface, it deactivates most of the front-panel controls. This remote-control mode is indicated by the **Remote** LED on the front panel.

To return the controller to local (front-panel) control, press the **Local** button on the front panel.

Modulating the Laser Output

The Vortex allows you to modulate the frequency or the current of the laser. For frequency modulation, connect your signal to the **Frequency Modulation** connector on the back of the controller. For current modulation, you can use either the DC-coupled **Current Modulation** BNC input on the back of the controller or the high-speed SMA input on the back of the laser head.

Figure 6:
Controller back
panel

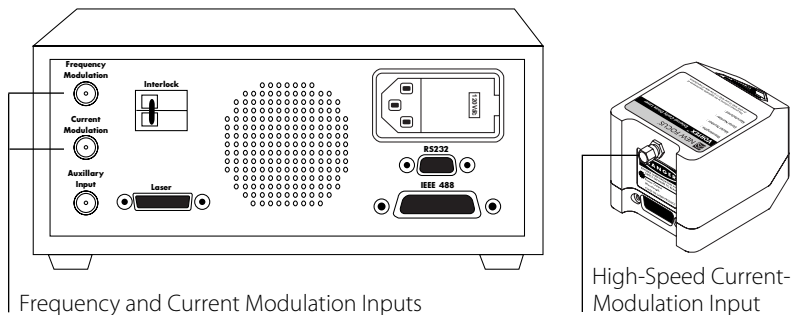

You can also use the current-modulation inputs for fine-frequency (fine-wavelength) control because the frequency changes with the current.

Modulating the Frequency

You can modulate the laser frequency (wavelength) by using an externally generated analog signal to modulate the voltage of the piezoelectric actuator (the piezo directly controls the laser frequency).

To modulate the frequency, connect the line for the input signal to the **Frequency Modulation** connector on the back of the Vortex controller. Make sure the signal conforms to the following specifications:

Frequency Modulation Input Guidelines	
Connector Type	BNC
Max. Voltage	± 4.5 V
Input Frequency Range	DC–3.5 kHz
Impedance	5 k Ω

The frequency modulation signal is added to the set DC level for the piezo (set either through the front panel or by computer control). Increasing the voltage increases the laser frequency (decreases the wavelength); decreasing the voltage decreases the frequency.

The total piezo voltage (the DC level plus the frequency modulation signal) is limited to a range of 0 to 117.5 V. The tuning range is laser dependent; see the Acceptance Test Data Sheet that accompanied your laser head for the tuning range specification.

Note: For fine-frequency control, you can modulate the current, since changes in current will affect the frequency. See “Modulating the Current” on page 22.

Modulating the frequency over the full tuning range

1. Use the Vortex front panel to set the piezo voltage to 59 V.
2. Set the input voltage to a maximum 4.5 V_{p-p} (-2.25 V to +2.25 V).

Note: If you used the computer interface to change the gain to “low” (a gain factor of 1), you will not be able to modulate the frequency over the entire tuning range (for information on using the computer interface, see “Computer Control” on page 29).

Modulating the Current

To modulate the current, you can use either the DC-coupled Current Modulation BNC input on the back of the controller or the high-speed SMA input on the back of the laser head.

Since changes in the current affect the laser frequency, you may want to modulate the current in order to achieve fine-frequency modulation. The frequency modulation is due to changes in the index of refraction of the laser-gain medium (the semiconductor diode) as a function of laser current. The degree to which the current affects the wavelength depends on the specific laser head you are using, but it is in the range of 25–150 MHz/mA.

Using the DC-Coupled Current Modulation Input

You can modulate the laser current (amplitude) using an externally generated low-level signal.

To modulate the current, connect the line for the input signal to the **Current Modulation** connector on the back of the Vortex controller. Make sure the signal conforms to the following specifications:

Current Modulation Input Guidelines (DC-coupled)	
Connector Type	BNC
Max. Voltage	± 10 V
Input Frequency Range	DC–1 MHz
Impedance	5 k Ω
Modulation	0.2 mA/V



The DC-coupled Current Modulation input is NOT current limited. To prevent damage to the laser diode DO NOT modulate the current above the operating current specified in the Acceptance Test Data Sheet.

The front-panel current readout does not reflect the modulation input. You can calculate the actual current by adding the current shown on the front-panel display to the modulation input.

Using the High-Speed Current Modulation Input

You can use the SMA connector on the back of the laser head to modulate the current at high speeds.

1. Turn off the diode power (the light in the **Power** button should be off).



Failure to turn off the diode power before connecting the RF input could permanently damage the laser diode.

2. Connect the line for the input signal to the SMA connector on the back of the Vortex laser head. Make sure the signal conforms to the following specifications:

Current Modulation Input Guidelines (High-Speed)	
Connector Type	SMA
Max. Voltage	1 V _{p-p}
Input Frequency Range	50 kHz–100 MHz
Impedance	50 Ω
Modulation	20 mA/V



This is a direct RF connection to the laser diode. Improper use could irreparably damage the diode. Do not exceed the 1 V_{p-p} input and use standard precautions for static discharge when using this input.

Reading an Input Signal

You can monitor an input signal using the **Auxiliary Input** connector on the back of the Vortex controller. This input is also used to run the Vortex in constant-power mode (see page 25).

The **Auxiliary Input** converts an external analog signal to a digital signal that can be displayed on the front panel or read through the computer interface. This is a general-purpose input that allows you to collect data

from another instrument, such as a photodetector during a wavelength scan.

Connect the line for the input signal to the BNC connector on the back of the Vortex controller. Make sure the signal conforms to the following specifications:

Auxiliary Input Guidelines	
Connector Type	BNC
Voltage Range	0 V to +4 V
Input Frequency	DC–10 kHz
Impedance	10 k Ω



The update rate for the Auxiliary Input can vary, depending on processor demands, from 10–100 milliseconds.

Constant-Power Mode

Introduction

When operating in constant-power mode, the controller adjusts the laser current to maintain a stable output power. Only the power and the laser's wavelength (controlled by the piezo voltage) can be varied in this mode. The laser power displayed in this mode is given in terms of a percentage of maximum auxiliary-signal input.

The feedback-circuit electronics that control constant-power mode are internal to the Vortex controller, but you will need an external beamsplitter and photodetector to provide the controller with the necessary electrical signal for the internal feedback circuit.

Preparing to Use Constant-Power Mode

Constant-power mode uses a feedback signal from the **Auxiliary Input** to stabilize the laser's output power. Operating the Vortex laser in constant-power mode is a three-step process:

1. Set up an external beamsplitter to pick off a portion of the output beam and direct it into a photodetector.
2. Feed the signal from the photodetector into the controller's auxiliary input.
3. Generate a setpoint, based on a percentage of the maximum output power, using either the front panel or computer control.

The Vortex controller will compare the output measured by the photodetector to the setpoint you entered and actively adjust the laser current to stabilize the output power.

Following are the specifications for the external components you will need to supply:

Beamsplitter: An external beamsplitter is needed to sample the laser output. The reflectivity of the beamsplitter at the Vortex wavelength should be approximately 10%. The beamsplitter should also have a constant reflectivity over the tuning range of the laser. A recommended beam pick-off is the New Focus Model 5801 wedged Beam Pick-off.

Photodetector: An external photodetector is needed to measure the power in the beam sampled by the beamsplitter. The detector gain must be large enough to generate a signal of 4 V when the laser is operating at its maximum output power. For example, with a full output power of 10 mW, and a 10% beamsplitter, the detector conversion gain must be 4000 V/W. Recommended detectors are the New Focus 2001 and 2011, as they provide sufficient gain and the gain is adjustable.

Operating in Constant-Power Mode

Setting up and Aligning the Laser

Before switching to constant-power mode, use the Vortex in constant-current mode to set up and align the laser.

1. Turn on the Vortex keyswitch and allow the system 20 minutes to warm up.
2. If the **Constant Power** indicator is on, press the **Mode** button to switch the laser to constant-current mode.
3. Push the **Power** button to activate laser power.
4. Turn up the laser current to the recommended operating current, as specified in the Acceptance Test Data Sheet.
5. Direct the output beam through the beamsplitter.
6. Direct the sample beam onto the photodetector: Use caution to prevent back reflections into the laser.
7. Connect the photodetector output to the **Auxiliary Input** on the back of the Vortex controller.

8. On the controller, press the **Display** button until the display shows the reading for the auxiliary input (“Aux x.x”).
9. Adjust the beam position on the photodetector to maximize the voltage being displayed.
10. Adjust the gain of the detector to achieve a reading of about 4 V, keeping the current set to the recommended operating current.

Switching to Constant-Power Mode

1. If laser power is on, push the **Power** button to turn off power to the laser (power must be off to switch modes).
2. Push the **Mode** button to change the Vortex into constant-power mode. The **Constant Power** indicator will go on and the display will change to show the output power (the units will be in %).
3. Push the **Power** button to re-activate laser power.
4. Set the desired power level by adjusting the % level. If the **Set** button is not already lit, you will need to press it to enable the adjustment knob.

In order to operate in constant-power mode, you must operate at less than 100% to ensure that the laser controller can adjust the current to provide a constant-power level. The operational power is dependent on your specific laser and the variation in power over your tuning range.



Do not block the beam incident on the photodetector when in constant-power mode: this interrupts the feedback loop and will push the laser output to maximum power.

Computer Control

Introduction

The Vortex laser system can be operated remotely through either the parallel IEEE-488 (GPIB) interface or the serial RS-232 interface. Most computers have RS-232 interfaces built in. In order to use the IEEE-488 interface, a special card or interface box is necessary. The IEEE-488 interface is many times faster than the RS-232 interface and can be used to communicate with up to 30 instruments at the same time. RS-232 is limited to communication with one instrument at a time.

All front-panel operations are available through computer control. In addition, several functions are unique to computer control.

Before attempting to communicate with the instrument, you must set the device address (for IEEE-488) or the baud rate (for RS-232) via the front panel. Upon receiving a command over the computer interface, the front-panel functions are locked out. Use the **Local** button on the front panel to re-enable the front panel.

Using the IEEE-488 Interface

The IEEE connector on the back of the Vortex controller allows for remote operation through a standard IEEE-488 (GPIB) cable. The connector is a standard, female, 24-pin IEEE-488 connector for use with a standard shielded IEEE-488 cable.

In order to function properly, the Vortex must have a GPIB address that is unique from all the other IEEE-488 components attached to your computer.

Setting the Vortex GPIB address

1. Press the **GPIB Address** button on the front panel to display the GPIB address for the Vortex.
2. If it is not already lit, press the **Set** button to enable the adjustment knob.
3. Turn the adjustment knob to change the setting.
Turn the knob clockwise to increase the value, counter-clockwise to decrease the value.
4. Press the **GPIB Address** button again to return to the normal display.

Using the RS-232 Interface

The **RS-232** 9-pin connector on the back of the Vortex controller allows for remote operation through a standard 9-pin RS-232 cable (see page 59). To use the RS-232 port, attach a standard, shielded RS-232 cable to the connector.

To communicate with the Vortex, set your computer to 8 data bit, no parity checking, 1-stop bit, no hardware handshake. The Vortex can support baud rates between 300 and 57,600 bps.

Setting the Baud Rate for RS-232

1. Press the **Baud Rate** button on the front panel to display the RS-232 baud rate
2. If it is not already lit, press the **Set** button to enable the adjustment knob.
3. Turn the adjustment knob to change the setting.
Turn the knob clockwise to increase the value, counter-clockwise to decrease the value. Available baud rates are 300, 1200, 2400, 4800, 9600, 19200, 38400, and 57600.
4. Press the **Baud Rate** button again to return to the normal display.

Restoring Local (Front-Panel) Control

When the Vortex receives a command from the computer interface, it deactivates most of the front-panel controls. This remote-control mode is indicated by the “Remote” LED on the front panel.

To return the controller to local (front-panel) control, press the **Local** button on the front panel.

Understanding the Command Types

There are three types of commands understood by the Vortex: *Set* commands, *Query* commands, and *Sense* commands.

- Use Set commands to set or change a value. Examples would be commands that turn on the laser head or set the operating current.
- Use Query commands to check the user- or factory- set values of the laser. Examples include checking the set value for the current and checking the number of hours of operation.
- Use Sense commands to determine the actual values for the laser properties at any given time. For example, to check the actual operating current or the voltage from the auxiliary input.

Sense and Query commands evoke a response from the driver. If you are using RS-232, the response is sent immediately; with IEEE-488, the response is loaded into the output buffer (a first-in, first-out buffer with a capacity of 5 messages). There is no response from Set commands if they are accepted and properly executed.

Conventions

The following pages contain a summary of all available commands, followed by detailed definitions for each command. The following conventions are used in both the “Command Summary” and the “Command Definitions” sections.

- The part of the command shown in uppercase represents the short form of the command. The commands are case insensitive.

If the syntax shown is “:SOURce:CURRent?”, then the Vortex will accept any of the following: “:SOUR:CURR?”, “:sour:curr?”, or “:sour:current?”. The Vortex will not accept commands such as “:SOURC:CURR?” or “:sour:curre?”.

- Values to be input are indicated by angle brackets (<>) and are separated from the command either by a space or by a colon, as shown in the command syntax.
- Common IEEE-488 commands all begin with an asterisk character, “*”; the device-specific commands all begin with a colon, “:”. These characters are not optional.
- Vortex responses are sent differently depending on the interface you are using.

IEEE-488: responses are written into the output buffer — a first-in first-out (FIFO) buffer with a capacity for 5 outgoing messages. You will need to send a separate command to read the response from the buffer.

RS-232: responses are sent immediately and can be processed or ignored.

Programming for the Vortex

When programming for the Vortex, keep the following rules in mind.

- A command is not parsed until a new line character is received (RS-232) or a hardware EOI is detected (IEEE-488).
- Numbers may contain at most 15 characters. Commands that expect integer values will truncate after any decimal point in the input. For example, an input value of “11.56” is truncated to “11”.
- Only one command can be issued per line.
- The “IEEE-488.2 Common Commands” are adopted from the IEEE 488.2 standard. For more information on the standard, see “IEEE Standard Codes, Formats, Protocols, and Common Commands,” (IEEE Std 488.2-1992) published by the Institute of Electrical and Electronics Engineers, Inc., 345 East 47th St., New York, NY 10017, USA.
- For IEEE-488, the Status Byte is very important to successful communication with the Vortex. The Message Available (MAV) bit

in the Status Byte indicates whether or not data is waiting in the output buffer. Always check that the MAV bit is set before reading back information. If the output buffer is empty, the read will fail.

Note:

*The best way to check the Status Byte is to use a serial poll. A serial poll returns the same information as the *STB? query, but it bypasses the output buffer (the Vortex places the *STB? response in the output queue and it can't be read until all other responses are read).*

Note:

*The RS-232 interface does not support serial polling, so you would have to use the *STB? command to query the Status Byte. However, since the Vortex sends RS-232 responses and errors directly, without using the output buffer, there is rarely, if ever, a reason to read the output buffer.*

Command Summary

IEEE-488.2 Common Commands

Syntax	Command	Page
*IDN?	Identification Query	36
*RST	Reset	36
*CLS	Clear Status	36
*ESR?	Query Standard Event Status Register	37
*ESE <value>	Set Standard Event Status Enable Register	38
*ESE?	Query Standard Event Status Enable Register	39
*STB?	Query Status Byte	40
*SRE <value>	Set Service Request Enable Register	41
*SRE?	Query Service Request Enable Register	42

System Information Queries

Syntax	Command	Page
:SYST:INF:SMAN?	Instrument Manufacturing Date	42
:SYST:INF:HMAN?	Laser Head Manufacturing Date	42
:SYST:INF:SHO?	Instrument Operating Hours	42
:SYST:INF:DHO?	Laser Head Operating Hours	43
:SYST:INF:HWAV?	Laser Head Wavelength	43

System Commands

Syntax	Command	Page
:CONF:MOD:<mode>	Set System Operating Mode	43
:CONF:MOD?	Query System Operating Mode	43
:OUTP <power>	Turn On/Off Power to the Laser Head	44

Syntax	Command	Page
:OUTP?	Query Laser Head Power	44
:SENS:VOLT:AUX	Sense Auxiliary Voltage	44

Current/Diode Commands

Syntax	Command	Page
:SOUR:CURR <current>	Set Diode Current	45
:SOUR:CURR?	Query Diode Current Setpoint	45
:SENS:CURR	Sense Diode Current	45
:SENS:TEMP	Sense Laser Temperature	46

Power/Laser Commands

Syntax	Command	Page
:OUTP <power>	Turn On/Off Power to Laser Head	44
:OUTP?	Query Laser Head Power	44
:SOUR:POW <voltage>	Set Laser Output Power	46
:SOUR:POW?	Query Laser Power Setpoint	46
:SENS:POW	Sense Laser Power	47

Wavelength (Piezo Voltage) Commands

Syntax	Command	Page
:SOUR:VOLT:PIEZ <current>	Set Piezo Voltage	47
:SOUR:VOLT:PIEZ?	Query Piezo Voltage Setpoint	47
:SENS:VOLT:PIEZ	Sense Piezo Voltage	47
:CONF:GAIN:<gain>	Set Frequency Modulation Gain	48
:CONF:GAIN?	Query Frequency Modulation Gain	48

Command Definitions

IEEE-488.2 Common Commands

Identification Query

Syntax	*IDN?
Vortex Actions	Returns the system identification string containing the manufacturer, model numbers, serial numbers, and firmware revision.
Example	*IDN? ⇒ New Focus , I6000 H6013 , I059 , H623 , 3 . 3 (Manufacturer = New Focus, Controller Model = 6000, Head Model = 6013, Controller S/N =059, Head S/N = 623, Firmware ver. 3.3)

Reset Command

Syntax	*RST
Vortex Actions	Resets internal operations of the Vortex: <ul style="list-style-type: none">• Turns off laser diode.• Sets the laser to constant-current mode.• Sets current, piezo voltage, and power to minimum values.• Sets the gain to high (25x).
Argument/Response	None

Clear Status Command

Syntax	*CLS
Vortex Actions	Clears status reporting structures (does not affect the Output Queue or the MAV bit of the Status Byte).
Argument/Response	None

Query Standard Event Status Register

Syntax	*ESR?
Vortex Actions	Returns the value of the Event Status Register and then clears the register (returns all bits to 0).
Response	An integer in the range 0 to 255, corresponding to the combined weight of the bits that are set.

Standard Event Status Register		
Bit #	Weight	Description
7	128	Power on or restart
6	64	not used
5	32	IEEE: a command parse error. RS-232: not used.
4	16	IEEE: system not available for command or invalid data (out of range). For example, attempting to change modes while the laser diode power is on. RS-232: not used.
3	8	not used
2	4	Query error: no data in queue.
1	2	not used
0	1	not used

Example Determine if the system has been restarted since the last time this query was made:

*ESR?

⇒ 160

(160=128+32, the system has been restarted and there was a command parse error)

Set Standard Event Status Enable Register

Syntax	*ESE <value>
Vortex Actions	<p>Sets the specified bits of the Event Status Enable Register.</p> <p>When a corresponding bit in the Standard Event Status Register becomes true, enables the Event Summary Bit (ESB) in the Status Byte.</p>
Argument	An integer in the range 0 to 255, corresponding to the combined weight of the bits you want to set.

Standard Event Status Enable Register		
Bit #	Weight	Description
7	128	Enable ESB in case of power on or restart.
6	64	not used
5	32	IEEE: enable ESB in case of a command parse error. RS-232: not used.
4	16	IEEE: enable ESB in case of "system not available" or "invalid data" error. RS-232: not used.
3	8	not used
2	4	Enable ESB in case of query error.
1	2	not used
0	1	not used

Example	<p>Enable the ESB if the system is restarted:</p> <p>*ESE 128</p>
---------	---

Query Standard Event Status Enable Register

Query Syntax	*ESE?
Vortex Actions	Queries the Event Status Enable Register
Response	An integer in the range 0 to 255, corresponding to the combined weight of the bits that are set. See the “Set Standard Event Status Enable Register” command definition on page 38 for a description of the bits and their weights.
Example	Check which bits of the register are enabled: *ESE? ⇒ 164 (164=128+32+4, the ESB bit will be enabled in case of a system restart, command parse error, or a query error)

Query Status Byte

Query Syntax	*STB?
Vortex Actions	Returns the value of the Status Byte Register.
Response	An integer in the range: 0 to 255, corresponding to the combined weight of the bits that are set.

Status Byte Register		
Bit #	Weight	Description
7	128	not used
6	64	Master Summary Status Bit (MSS): indicates that one of the bits being watched by the Service Request Enable Register has been enabled.
5	32	Event Summary Bit (ESB): indicates that one of the bits being watched by the Standard Event Status Enable Register has been enabled.
4	16	Message Available Bit (MAV): indicates that data is being held in the output buffer. This will not happen under RS-232.
3	8	not used
2	4	not used.
1	2	not used
0	1	not used

Example	Check the Status Byte: *STB? ⇒ 16 (there is data in the output buffer)
---------	---

Set Service Request Enable Register

Syntax

*SRE <value>

Vortex Actions

Sets the specified bits of the Service Request Enable Register.

When a corresponding bit in the Status Byte Register becomes true, enables bit Master Summary Status Bit (MSS) of the Status Byte (when serial polling, generates a service request).

Argument

An integer in the range: 0 to 255, corresponding to the combined weight of the bits you want to set.

Service Request Enable Register		
Bit #	Weight	Description
7	128	not used
6	64	not used
5	32	Enable the MSS Bit if the Event Summary Bit (ESB) is enabled.
4	16	Enable the MSS Bit if the Message Available Bit (MAV) is enabled. This will not happen under RS-232.
3	8	not used
2	4	not used.
1	2	not used
0	1	not used

Example

Set the MSS Bit (generate a service request) when there is data in the output buffer:

*SRE 16

Query Service Request Enable Register

Syntax	*SRE?
Vortex Actions	Queries the Service Request Enable Register.
Response	An integer in the range: 0 - 255, corresponding to the combined weight of the bits that are set. See the “Set Service Request Enable Register” command definition on page 41 for a description of the bits and their weights.

System Information Queries

Query Instrument Manufacturing Date

Syntax	:SYSTem:INFormation:SMANufacture?
Vortex Actions	Returns the date of system manufacture.
Response	“mm-dd-yy” (Month-Day-Year)

Query Instrument Operating Hours

Syntax	:SYSTem:INFormation:SHOurs?
Vortex Actions	Returns the system operating time.
Response	“x Hrs.” range: 0 to 65536 (7.5 years)

Query Laser Head Manufacturing Date

Syntax	:SYSTem:INFormation:HMANufacture?
Vortex Actions	Returns the date of laser head manufacture.
Response	“mm-dd-yy” (Month-Day-Year)

Query Laser Head Operating Hours

Syntax	:SYSTem:INFormation:DHOurs?
Vortex Actions	Returns the laser head operating time.
Response	“xxxxxHrs.” range: 0 to 65536 (7.5 years)

Query Laser Head Wavelength

Syntax	:SYSTem:INFormation:HWAVelength?
Vortex Actions	Returns the nominal head wavelength.
Response	“x.xx nm”

System Commands

Set System Operating Mode

Syntax	:CONF:MODE:<mode>
Vortex Actions	Sets the system to constant current or constant power mode.
Argument	CURRent or POWer
Example	Set the laser to operate in constant-current mode: :CONF:MOD:CURR

Query System Operating Mode

Syntax	:CONF:MODE?
Vortex Actions	Queries the system operating mode.
Response	“CURRENT” or “POWER”
Example	Determine whether the laser is operating in constant-current or constant-power mode: :CONF:MOD? ⇒ POWER (the laser is in constant-power mode)

Turn Laser On/Off

Command Syntax	:OUTPut <value>
Vortex Actions	Turns the laser head on or off
Argument	“0” for laser current off and “1” for laser current on
Example	Turn off power to the laser: :OUTP 0

Query Laser Power

Syntax	:OUTPut?
Vortex Actions	Reads laser-current status
Response	“0” for laser current off and “1” for laser current on
Example	Determine if the laser current is on or off. :OUTP? ⇒ 1 (the laser is turned on)

Sense Auxiliary Voltage

Syntax	:SENSe:VOLTagE:AUXiliary
Vortex Actions	Returns the auxiliary input-voltage reading.
Response	“x.xxxV” range: 0.0 to 4.000

Current/Diode Commands

Set Diode Current

Syntax	<code>:SOURce:CURRent <current></code>
Vortex Actions	Sets the diode-current setpoint when in constant-current mode.
Argument	<code>x.x</code> range: 0.0 to 160.0, units are in mA
Example	Set the diode current to 88.8 mA. <code>:SOUR:CURR 88.8</code>

Query Diode Current Setpoint

Syntax	<code>:SOURce:CURRent?</code>
Vortex Actions	Queries the diode-current setpoint when in constant-current mode.
Response	<code>"x.xmA"</code> range: 0.0 to 160.0
Example	Read the setpoint for the diode current: <code>:SOUR:CURR?</code> <code>⇒ 99.3mA</code>

Sense Diode Current

Syntax	<code>:SENSe:CURRent</code>
Vortex Actions	Returns the laser-diode current reading.
Response	<code>"x.xmA"</code> range: 0.0 to 180.0

Sense Laser Temperature

Syntax	:SENSe:TEMPerature
Vortex Actions	Returns the laser-temperature reading.
Response	“x.xC” range: 7.0 to 47.0

Power/Laser Commands

Set Laser Power

Syntax	:SOURce:POWer <power>
Vortex Actions	Sets the laser-power setpoint when in constant power mode.
Argument	x.x range: 0.0 to 100, units are in %
Example	Set the laser power to 65.3%: :SOUR:POW 65.3

Query Laser Power Setpoint

Syntax	:SOURce:POWer?
Vortex Actions	Queries the laser-power setpoint.
Response	In constant-power mode: “xx.x%” range: 0.0 to 100.0 In constant-current mode: “xx.xmW” range: 0.0 to Max Power (laser specific)
Example	Check the laser power setpoint: SOUR:POW? ⇒ 52.8%

Sense Laser Power

Syntax	: SENSE : POWer
Vortex Actions	Returns the laser-power reading.
Response	In constant-power mode: “xx.x%” range: 0.0 to 100.0 In constant-current mode: “xx.xmW” range: 0.0 to Max Power (laser specific)

Wavelength (Piezo Voltage) Commands

Set Piezo Voltage

Syntax	: SOURce : VOLTage : PIEZO <voltage>
Vortex Actions	Sets the piezo-voltage setpoint.
Argument	x.x range: 0.0 to 117.5, units are volts
Example	Set the piezo voltage to 88.6 volts: : SOUR : VOLT : PIEZ 88 . 6

Query Piezo Voltage Setpoint

Syntax	: SOURce : VOLTage : PIEZO?
Vortex Actions	Queries the piezo-voltage setpoint.
Response	“x.xV” range: 0.0 to 117.5

Sense Piezo Voltage

Syntax	: SENSE : VOLTage : PIEZO
Vortex Actions	Returns the piezo-voltage reading.
Response	“xxx.xV” range: 0.0 to 117.5

Set Frequency Modulation Gain

Syntax	: CONF : GAIN : <gain>
Vortex Actions	Sets the frequency-modulation gain setting (default setting is high).
Argument	HIGH or LOW Gain factor: High=25, Low=1
Example	Set the FM Gain to low (1x): : CONF : GAIN : LOW

Query Frequency Modulation Gain

Syntax	: CONF : GAIN ?
Vortex Actions	Queries the frequency-modulation gain setting (default setting is high).
Response	“HIGH” or “LOW” Gain factor: High=25, Low=1

Principles of Operation

Overview

Traditional diode-laser technology provides high reliability, high electrical efficiency, and a wide range of available wavelengths in a compact package. By using an external cavity built around a diode laser, the Vortex enhances the performance of off-the-shelf diode lasers, guaranteeing single-mode operation with narrow linewidth and precise wavelength tuning. The short-term linewidth of the Vortex laser is <300 kHz (over a 50-msec time interval), compared with typical linewidths for Fabry-Perot diode lasers of 10–500 MHz.

General Theory

The Vortex laser cavity is based on the Littman-Metcalf design (see refs. on page 51), which uses a diffraction grating at grazing incidence to provide wavelength selectivity. Essential to the performance of tunable external-cavity

diode lasers (ECDLs) is a high-quality anti-reflection (AR) coating on the front facet of the diode. The AR coating turns the diode into purely a gain element. A collimating lens directs the output of the diode across a diffraction grating at grazing incidence. The end mirror of the laser cavity reflects the first-order diffraction off the grating to provide

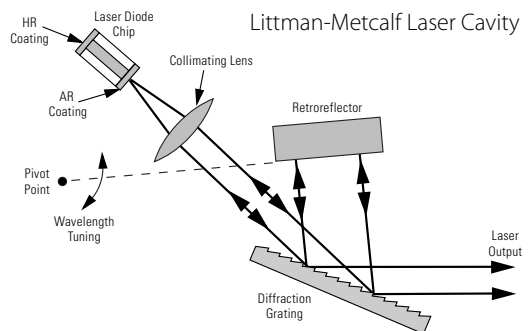

feedback. Dispersion provided by the grating allows only one cavity mode to lase, resulting in a very narrow linewidth. The specular reflection or zero-order diffraction off the grating serves as the output beam of the laser.

The angle between the grating and the end mirror determines the lasing wavelength. Tuning is achieved by varying the angle using a piezoelectric actuator to rotate the end mirror. Continuous (mode-hop-free) tuning requires selecting an appropriate rotation point. Discontinuous tuning, characterized by periodic “mode-hops” results from two competing wavelength-selection constraints, the mirror-grating angle and the laser-cavity length. The laser-cavity length, L , defines a discrete set of possible wavelengths or *modes*, λ_N , that can lase, given by the equation $L = N\lambda_N/2$, ($N = \text{integer}$). The grating equation insists that $\lambda = \Lambda(\sin \theta_i + \sin \theta_d)$, where Λ refers to the groove spacing of the grating while θ_i and θ_d refer to the incident and diffracted angles of the laser beam. Rotation of the end mirror causes parameters in both equations to change. An appropriately selected point of rotation synchronizes the two, such that the cavity length remains the same number of half-wavelengths long as the mirror is being rotated. Thus mode-hop free tuning is achieved. When this condition is not met, the lasing wavelength will periodically hop from one mode to the next (e.g. from N to $N + 1$) as the laser is tuned. The mechanical design of the Vortex provides truly mode-hop free tuning.

The Vortex controller provides current, voltage, and temperature controls to the laser head, as well as manual and computer controlled input/output interfaces. The low-noise current supply drives the diode in the laser head, controlling the output power. The voltage controller drives the piezo in the laser head, controlling the lasing wavelength. Finally, the temperature control regulates the laser-cavity temperature, providing a stable-output wavelength.

The laser wavelength is also affected by the current through the diode. Changing the diode current affects the refractive index of the diode lasers and therefore, the laser cavity length. The magnitude of the effect is diode dependent, but is typically 25–150 MHz/mA.

References

T. Day, F. Luecke, and M. Brownell, “Continuously tunable diode lasers,” *Lasers and Optronics*, pages 15–17, June 1993.

K. C. Harvey and C. J. Myatt, “External-cavity diode laser using a grazing-incidence diffraction grating,” *Optics Letters*, vol. 16, pages 910–912, 1991.

M. G. Littman and H. J. Metcalf, “Spectrally narrow pulsed dye laser without beam expander,” *Applied Optics*, vol. 17, pages 2224–2227, 1978.

M. G. Littman, “Single-mode operation of grazing-incidence pulsed dye laser,” *Optics Letters*, vol. 3, pages 138–140, 1978.

M. G. Littman, “Single-mode pulsed tunable dye laser,” *Applied Optics*, vol. 23, pages 4465–4468, 1984.

K. Liu and M. G. Littman, “Novel geometry for single mode scanning of tunable lasers,” *Optics Letters*, vol. 6, pages 117–118, 1981.

Changing the AC-Voltage Selection

The Vortex Controller can operate at 100, 120, 220, or 240 V AC, at AC frequencies of 47–63 Hz. The unit is configured at the factory for the standard AC voltage of the purchaser's country.

To check the voltage setting, look at the voltage indicator on the back of the Vortex controller.

Figure 7:
AC power module
& voltage indicator

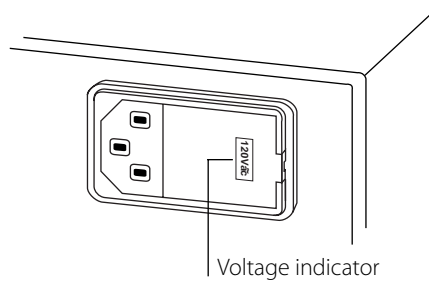

To change the operating voltage:

1. Disconnect the AC power cord.
2. Open the cover of the power module on the rear panel with a small blade screwdriver or similar tool.

Figure 8:
Power Module with
the cover open

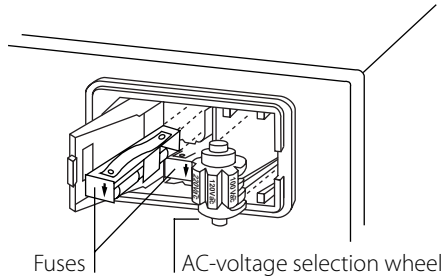

3. Remove the AC-voltage selection wheel from the unit.
Do not attempt to rotate the wheel while it is still in the power entry module; the wheel must be removed, turned, and then reinserted for proper operation.
4. Re-insert the wheel into the module so the desired AC voltage can be viewed in the power-module window.
5. Ensure the proper fuses are installed in your system.

The power entry module requires two 5x20 mm, slow-blow fuses, such as Littelfuse's Slo-Blo[®] 239 series: one for the hot line and the other for the neutral line. Replacement fuses should be as follows:

Figure 9:
AC Voltages and
their recom-
mended fuses

AC Voltage	Fuse Rating	Slo-Blo Fuse #
100 V AC	0.8 A	239.800
120 V AV	0.8 A	239.800
220 V AC	0.4 A	239.400
240 V AC	0.4 A	239.400

6. Close the power-module cover.
7. Verify the proper voltage is showing through the module window.
8. Reconnect the AC-power cord.

Customer Service

Service

The Vortex is designed as a maintenance-free laser, thus there are no scheduled service actions.

If your laser does require service, repair, or calibration, please call for a Return Authorization Number before shipping the unit to New Focus.

Technical Support

Information and advice about the performance or operation of your Vortex laser is available from our applications engineers. For quickest response ask for “Technical Support” and have your model and serial number available. The model and serial number can be read from the top of the laser head label or displayed on the controller front panel by simultaneously pressing the **GPIB Address** and **Baud Rate** buttons.

Hours: 8:00–5:00 PST, Monday through Friday
(excluding holidays).

Toll Free: 1-866-NUFOCUS (1-866-683-6287)
(from the USA & Canada only)

Phone: (408) 284-6808

Support is also available by fax and email:

Fax: (408) 980-8883

Email: techsupport@newfocus.com

We typically respond to faxes and email within one business day.

Appendix I: Physical Specifications

Controller

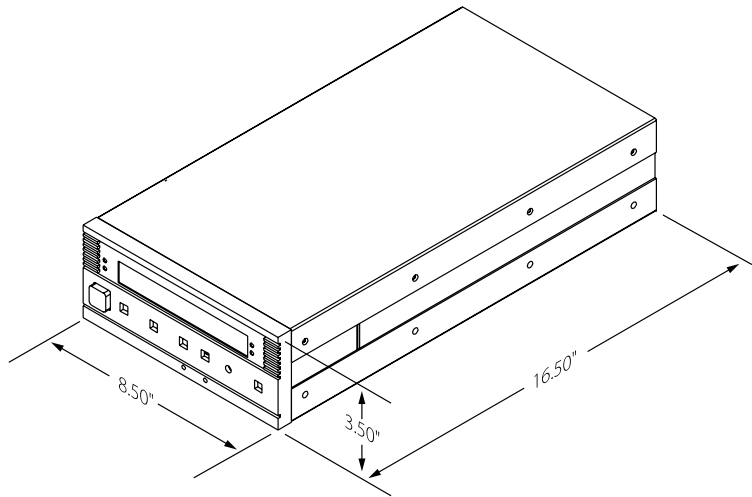

Controller Weight: 14 lbs (7 kg)

Laser Head and Mounting Bracket

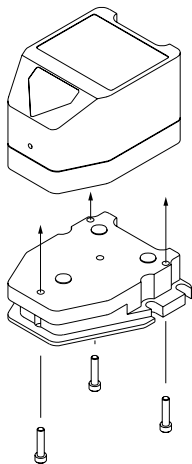

Detail of the Laser Head/Bracket Assembly.

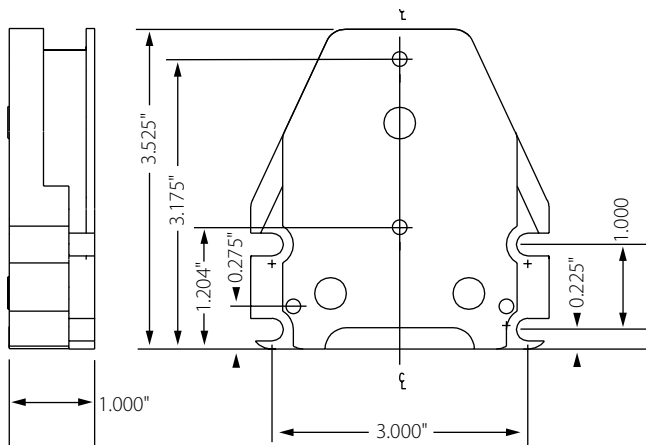
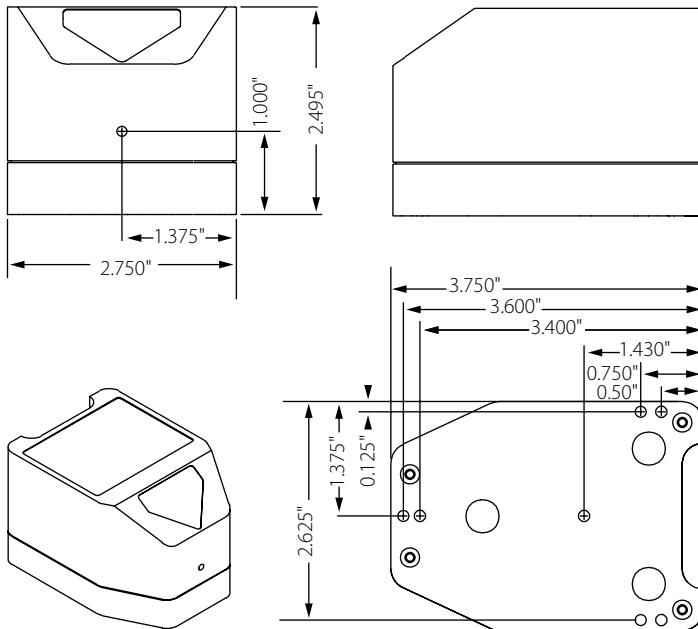

Weight of Laser Head and mounting bracket: 2 lbs (1 kg)

Appendix II:

RS-232 Connector Wiring

RS-232 9-Pin D-Connector

The RS-232 connector on the back of the Vortex controller is a standard female 9-pin D-connector. The laser controller transmits data on pin 2 and receives data on pin 3 (see below). If you have trouble communicating with the laser over the RS-232 port, you may need to use a null-modem adapter or cable.

Figure 10:
RS-232 Female
9-Pin D-Connector

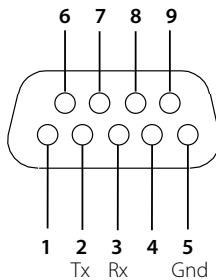

Pin	Name	Description
1		Not Connected
2	Tx	Serial Transmit Line
3	Rx	Serial Receive Line
4		Not Connected
5	Ground	Digital Ground Line
6-9		Not Connected

Index

A

AC voltage, checking or changing 53
address, setting for GPIB 30
auxiliary input 19, 23

B

baud rate, setting for RS-232 30
beam height 14
beamsplitter 26
bracket, mounting 14

C

computer control 29
 command definitions 36
 command summary 34
 restoring control to the front panel 20
 using the IEEE interface 29
 using the RS-232 interface 30
constant-power mode 25
 preparing for 25
 setting up and aligning for 26
 switching to 27
controller
 front panel controls 15
 restoring control to the front panel 20

current

 modulating 22
 setting 19

D

displaying input signals 19, 23

F

frequency
 modulating 21
 see also wavelength

front panel

 restoring control 20
front panel controls 15
fuses 54

G

GPIB
 see also IEEE
 setting the GPIB address 30

H

heatsinking 14
height, beam 14

help
 servicing the laser 55
 technical support 55
high-speed current modulation 23

I
IEEE
 common commands 34, 36
 computer control 29
 setting the GPIB address 30

inputs
 auxiliary 23
 current modulation 22
 frequency modulation 21

interlock, safety 7
isolation, optical 14

K
keyswitch 17

L
labels, safety 6
local mode 15

M
modes
 constant power 25
 constant-power 25
 selecting an operating mode 17
 setting the operating mode 18

modulating
 current 22
 frequency 21
mounting bracket 14
mounting the laser head 14

O
optical isolation 14

P
parameters, displaying and setting 19
photodetector 26
piezo voltage (wavelength)
 modulating 21
 setting 19
power
 constant-power mode 25
 maximum diode powers 6
 setting 19
 turning on the Vortex 17

R
remote mode 15
restoring control to the front panel 20
RS-232
 computer control 29
 setting the baud rate 30
 using 30
 wiring diagram 59

S
safety interlock 7
safety labels, identifying 6
servicing the laser 55
support, technical 55

T
technical support 55
temperature considerations
 heatsinking 14
 warming up 17
turning on the Vortex 17

V

voltage

- checking or changing AC voltage 53
- setting piezo voltage 19

W

warming up the Vortex 17

wavelength

- modulating 21
 - ranges by model number 6
 - tuning 19
- wiring diagram, RS-232 connector 59

