

PHY151H1F – Practical 10: Motion in a Circle, Torque

Don't forget:

- Write your **Pod Number** clearly on the front of the booklet.
- List the **Names** of all participants on the cover of the booklet. You do not need to write your student numbers. Note if any participants arrived late or left early.
- Fill in the **Date** on the front page of the booklet.

Today's Textbook Reference to review before Practical:

"Principles & Practice of Physics" 1st Edition by Eric Mazur ©2015
Chapters 11 and 12

Note that the activities below have numbers which refer to numbers in the Mechanics Modules at <http://faraday.physics.utoronto.ca/Practicals/>.



Mechanics Module 3, Activity 17

Attach one end of a string to the pig and the other end to the hook in the middle of the top bar. Pressing the “on” button on the side of the pig will get its wings moving. Now take the pig and give it a push in a circular direction in order for it to start performing uniform circular motion. After a few seconds, its motion should be stabilized. Then you may begin your measurements.

- Determine the period of the pig's motion by finding the average time needed to complete 10 revolutions, using the stopwatch provided. Do 3 or 4 trials and take an average to get a good measurement of period.
- Using the tape measure provided please measure the radius of the circle the pig is traveling. Determine a way to measure the pig's angle relative to the vertical.
- Using data from part A and B calculate the centripetal acceleration of the pig.
- Draw a free-body diagram for the pig (Do not include “engine force” and air resistance on this free-body diagram. They cancel out anyway.).
- Use your free-body diagram and Newton's second law in the vertical direction to find the tension in the string.
- Use your free-body diagram and the tension above to solve for the net force in the radial direction.
- Compare the net force in part F to ma_c (using a_c from part C). How should these two values compare? How do your two values compare?
- Briefly discuss why the “engine force” and air resistance did not enter into the calculations.

Course Concepts
Mechanics Module 6, Activity 6

- A. If you drop a yo-yo from rest without using the string, will it fall at the same rate as dropping a yo-yo from rest with the string attached to your finger? Which do you predict will fall faster? Write down your prediction in your booklet, then check your prediction by performing this experiment (have someone catch the free-fall yo-yo, otherwise it will break!).
- B. Draw free-body-diagrams for the yo-yo dropping without the string, and with the string. Explain, using forces Newton's Laws, the observations from part A.
- C. For the yo-yo dropped while attached to the string, does the force exerted on the yo-yo by the string ever do work? Assume that you hold your finger perfectly still as the yo-yo falls. Explain, using Conservation of Energy, the observations from part A.

Course Concepts
Mechanics Module 6, Activity 8

- A. A yo-yo sits on a tabletop and rolls without slipping. When a yo-yo rolls, is it best to think that the yo-yo is rotating about point A, or point B? Why?

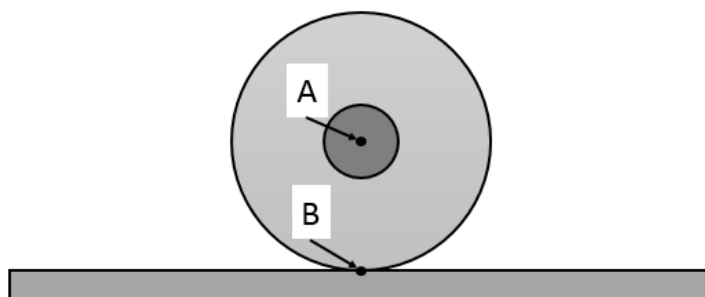

- B. Wrap the string around the yo-yo in a clockwise manner and place the yo-yo on the table in front of you. If you were to gently pull the string horizontally to the right, as shown, so that the yo-yo rolls without slipping, which way do you predict the yo-yo will rotate? (Clockwise or counter-clockwise) Write down your

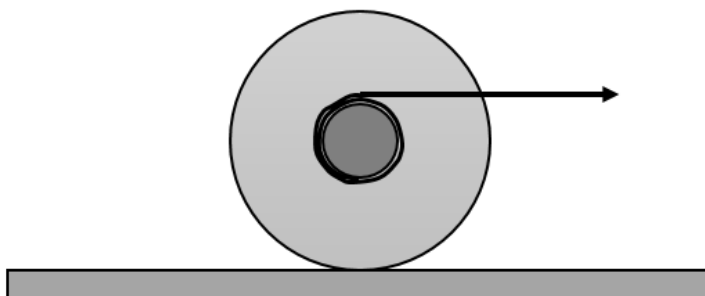

prediction in your booklet, then check your prediction by performing this experiment. Draw an extended free-body-diagram of the yo-yo in this configuration, and discuss the torques exerted

by the tension, gravity and friction forces.

- C. If you were to gently pull the string vertically upward, as shown, so that the yo-yo rolls without slipping on the table, which way do you predict the yo-yo will rotate? (Clockwise or counter-clockwise) Write down your prediction in your booklet, then check your prediction by performing this experiment. Draw an extended free-body-diagram of the yo-yo in this configuration, and discuss the torques exerted by the tension, gravity and friction forces.

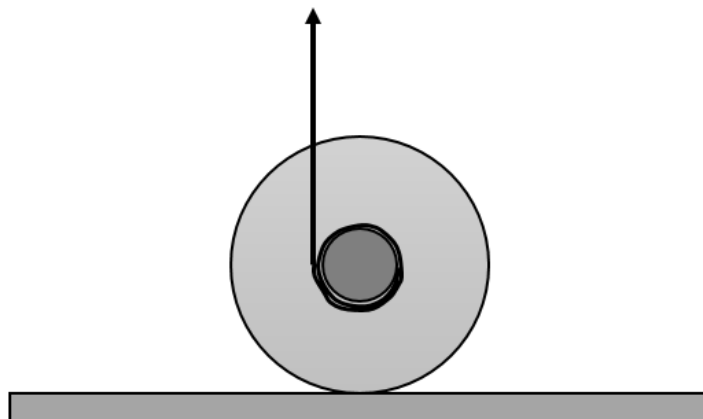

- D. If you were to gently pull the string horizontally to the left, as shown, so that the yo-yo rolls without slipping on the table, which way do you predict the yo-yo will rotate? (Clockwise or counter-clockwise) Write down your prediction in your booklet, then check your prediction by performing this experiment. Draw an extended free-body-diagram of the yo-yo in this configuration, and discuss the torques exerted by the tension, gravity and friction forces.

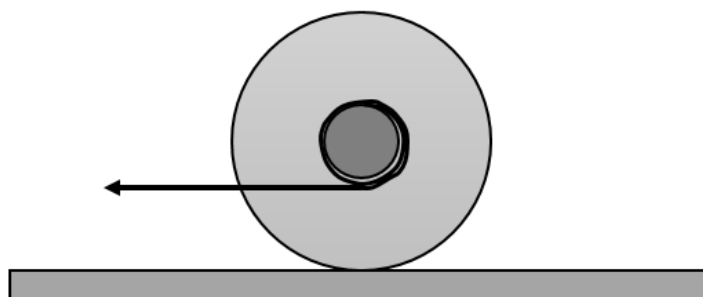

- E. If you were to gently pull the string on a diagonal up and to the left, as shown, so that the force-line passes through the bottom of the yo-yo, which way do you predict the yo-yo will rotate? (Clockwise or counter-clockwise) Write down your prediction in your booklet, then check your prediction by performing this experiment. Draw an extended free-body-diagram of the yo-yo in this configuration, and discuss the torques exerted by the tension, gravity and friction forces.

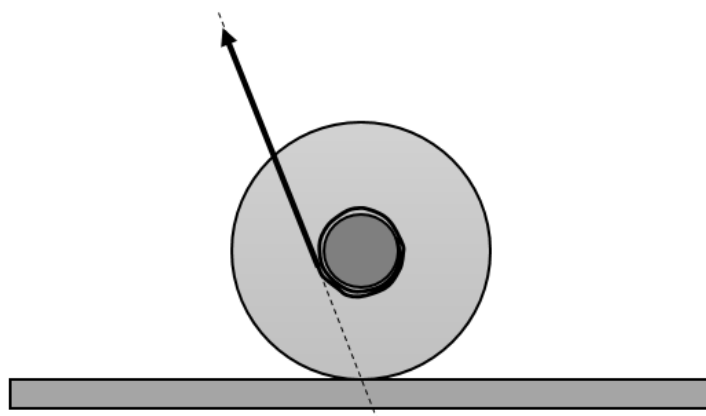

- F. If you assume that the rotation point is “point B” from the diagram in Part A, the torques due to friction and gravity are both zero. What is the direction of the torque from tension in parts B, C, D and E? How does this compare with the observed rotation directions?

If You Have Time (For a Bonus Point) – Practice Question 3 from the Fall 2013 PHY151 Final Exam

Recently, my Aunt sent me a lovely ornament. It had a mass M_O ; to display it, I built a shelf of mass M_S and length L and positioned the ornament at its centre, as shown in the figure. Unfortunately, I am a rotten carpenter, and the right hand support for the shelf soon disintegrated, so that the shelf fell down, pivoting about the left hand support as it did so. You may assume that the dimensions of the ornament are small, so that it may be treated as a point-like object. Express your answers in terms of M_O , M_S , L , g and μ_s , the coefficient of static friction between the ornament and the shelf.

- (a) If rotational inertia of the shelf about its centre is $\frac{1}{12}M_S L^2$ and the ornament is not slipping along the shelf, find the total rotational inertia of the shelf plus the ornament about the pivot.
- (b) Neglecting air resistance and assuming that static friction is holding the ornament fixed with respect to the shelf, find the angular velocity of the shelf about the pivot after it has fallen through an angle θ .
- (c) Draw the free-body diagram for the ornament before it starts to slip off the shelf. What is the acceleration of the ornament?
- (d) Show that the critical angle at which the ornament starts to slide down the shelf is given by:

$$\tan(\theta_{crit}) = \mu_s \left(\frac{4M_S + 3M_O}{10M_S + 9M_O} \right)$$

