

CHARGE-TO-MASS RATIO FOR THE ELECTRON

Introduction

This is a variation of the original experiment carried out by J. J. Thomson in 1895. The deflection of a charge moving in a magnetic field is clearly demonstrated.

A particle of mass m and charge e moving in a magnetic induction field \mathbf{B} will experience a force F given by

$$\mathbf{F} = e\mathbf{v} \times \mathbf{B} \quad (1)$$

where \mathbf{v} is the velocity of the particle. The vector cross product means the force \mathbf{F} is perpendicular to both \mathbf{v} and \mathbf{B} . If \mathbf{B} is constant and \mathbf{v} is perpendicular to \mathbf{B} , the particle will move in a closed circular orbit. The force on the particle is equal to its mass multiplied by its acceleration (we take the acceleration to be purely centripetal here):

$$evB = m\frac{v^2}{r} \quad (2)$$

where r is the radius of the orbit.

Now in this experiment, the particle is accelerated through a potential difference V in order to reach the speed v . Thus in the non-relativistic approximation,

$$eV = \frac{1}{2}mv^2 \quad (3)$$

Combining Eqs. (2) and (3), gives a curvature of the electron orbit of:

$$\frac{1}{r} = \sqrt{\frac{e}{2m}} \frac{B}{\sqrt{V}} \quad (4)$$

For more details on the derivation presented here, see [1].

Experiment

In this experiment, the magnetic induction \mathbf{B} is generated by the current flowing through a pair of Helmholtz coils. The geometry of the Helmholtz configuration

is sketched below in Fig. 1. Note that each coil radius is equal to the separation between the coils, this configuration giving minimum variation of B near the centre of the pair of coils. Over a volume containing the geometrical centre of the configuration, the magnetic field due to the coils is directed along the coil axis and is more-or-less uniform with the value

$$B_c = \left(\frac{4}{5}\right)^{3/2} \frac{\mu_0 n I}{R} \quad (5)$$

where $\mu_0 = 4\pi \cdot 10^{-7} \text{ Wb A}^{-1} \text{ m}^{-1}$. R is the radius of the coils, and n is the number of turns in each coil.

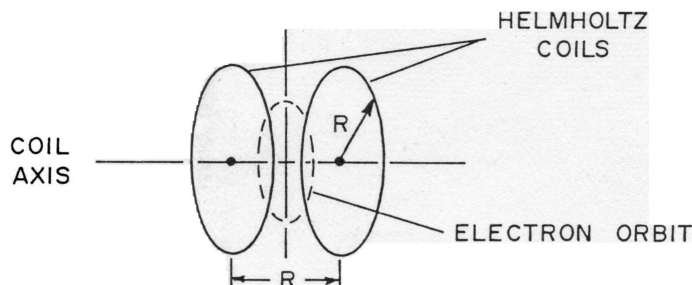

Figure 1: Geometry of Helmholtz configuration

Figure 1: Geometry

The total axial magnetic induction field in the region of the electron beam is the field from the coils, B_c , plus the external field from the earth and building and other instruments/devices in the laboratory, B_e . Thus,

$$B = B_c + B_e \quad (6)$$

$$\frac{1}{r} = \sqrt{\frac{e}{2m}} \frac{1}{\sqrt{V}} \left[\left(\frac{4}{5}\right)^{3/2} \frac{\mu_0 n I}{R} + B_e \right] \quad (7)$$

or, defining

$$k = \frac{1}{\sqrt{2}} \left(\frac{4}{5}\right)^{3/2} \frac{\mu_0 n}{R}$$

and

$$I_0 = B_e/k$$

to obtain

$$\frac{1}{r} = \sqrt{\frac{e}{m}} k \frac{I - I_0}{\sqrt{V}} \quad (8)$$

or, alternatively

$$\frac{\sqrt{V}}{r} = \sqrt{\frac{e}{m}} k (I - I_0) \quad (9)$$

Here k is the characteristic of the coil dimensions, and I_0 is a constant, proportional to the external magnetic field.

Apparatus

The apparatus (see pictorial circuit diagram in Fig. 2) consists of a glass bulb containing an electron gun and hydrogen gas at low pressure. Electrons emitted by a hot filament within the gun are shaped into a beam by accelerating them through a specially shaped anode. The anode voltage, V , is supplied by a 0 to 300 volt power supply (see Fig. 2 for a model configuration). The coil current is provided by an 8 V D.C. power supply (around 10 V under load) in series with a rheostat and an ammeter (see Fig. 3). The beam of electrons becomes visible when the electrons have enough kinetic energy to excite the gas by collision. The collisions, however, are sufficiently rare that the beam is scarcely affected; a full, circular trajectory should be clearly visible.

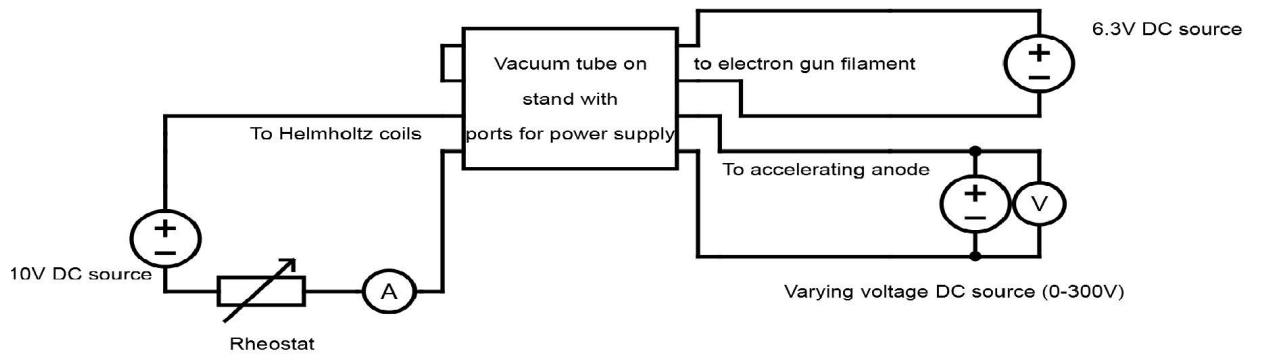

Figure 2: A circuit diagram of the apparatus.

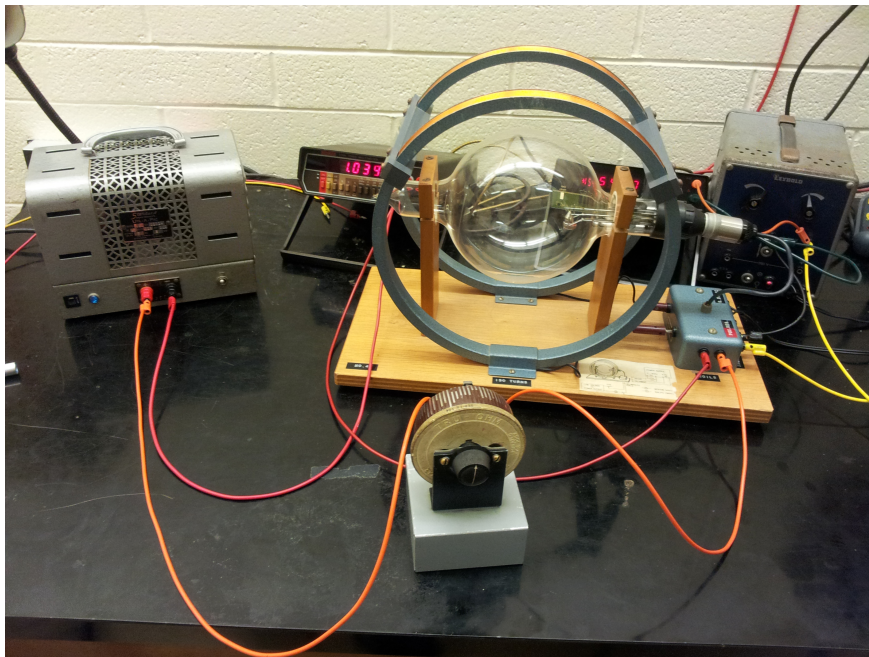

Figure 3: A photo depicting the apparatus.

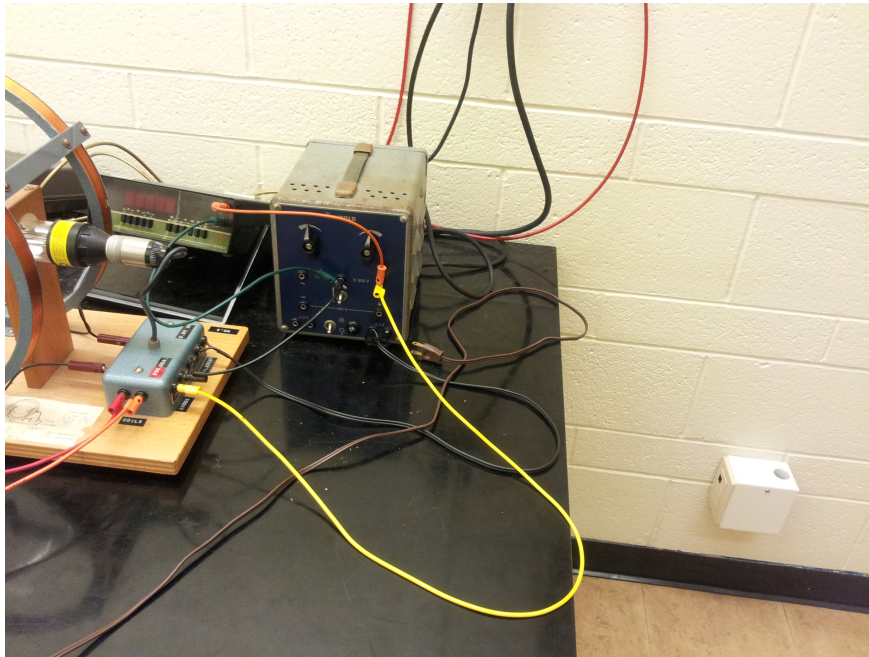

Figure 4: Another photo, demonstrating the monitoring of accelerating voltage in parallel via a voltmeter.

The bulb can be rotated to ensure the beam follows closed paths (alternatively one can switch the polarity of the leads to reverse the direction of the magnetic field). you should make sure that the trajectory of the electrons is a vertical circle and not a helix-like shape. The diameters of the paths can be measured with the self-illuminated scale and plastic reflector provided. The illuminated scale, if well positioned, eliminates problems of parallax in the measurement. You should work out how to use the scale before you start your readings.

NOTE: The filament of the electron gun should be turned on for 30s or more before the anode voltage and should never be turned off until the anode voltage is off. Otherwise, the tube may be damaged.

Electron beams of various curvatures may be obtained by varying the accelerating potential V , and the coil current I . If the curvature is in a 'backwards' direction so that the beam hits the glass envelope of the tube, you may rotate the tube 180 degrees in its mount (or switch the polarity of the leads to reverse the direction of the magnetic field).

Remark: the voltmeter used in the experiment has been found to accumulate

charge. Hence it is advisable to turn on the devices and then conduct measurements quickly, before the voltmeter has time to charge up, which could result in voltage output value fluctuations.

Questions

1. Explain how you used the self-illuminated scale and a plastic reflector to eliminate problems of parallax.
2. Investigate the anomalous behaviour of the electron trajectory in the case of low accelerating voltage V and high current in the coils I (resulting in a strong magnetic field B). Are all of the parts of the trajectory equally affected? Does this introduce an error into the measurements? If so, consider the ways it can be eliminated/reduced. In considering corrections to the value you obtain for e/m , you may wish to take account of the fact that although the field generated by the coils is very nearly constant along the axis, it decreases away from the axis. It can be shown that for off-axis distances ρ , which are less than $0.2R$, the z-component (the only one we have been considering) of the field, $B(\rho)$, is smaller than the axial field $B(0)$ by less than 0.075%. For $0.2R < \rho < 0.5R$ the ratio $B(\rho)/B(0)$ is given approximately by

$$\frac{B(\rho)}{B(0)} = 1 - \frac{\rho^4}{R^4 \left(0.6583 + 0.29 \frac{\rho^2}{R^2}\right)^2}$$

3. Calculate, from Equation (7), the "extra" field, B_e , NOT produced by the coils.
4. Evaluate the influence of nearby ferromagnetic materials and other sources of magnetic fields on the electron trajectory (for example, bring a cellphone near the glass bulb). Is it significant enough to affect the measurements?
5. Lastly, obtain the value of e/m , using the value B_e found above in conjunction with equations (8) and (9).

For (3) you may proceed as follows: use equation (6) in the form

$$\frac{1}{r} = \sqrt{\frac{e}{2m}} \frac{1}{\sqrt{V}} (B_c + B_e)$$

to find the external field (B_e) component along the direction of the field due to the coils (B_c) – first express B_c as a function of $1/r$, then compute B_c via (5) and plot B_c versus $1/r$ - the y-intercept should give the value of B_e . Comment on the magnitude of this field (i.e. how does it compare with the average value of the Earth's magnetic field, etc.).

References

- [1] Griffiths, David J. "Chapter 5: Magnetostatics." Introduction to Electrodynamics. Upper Saddle River, NJ: Prentice Hall, 1999.
- [2] Instruction manual for Keithley 179A TRMS Multimeter
<http://projectlab.engphys.ubc.ca/wp-content/uploads/Keithley-179A-.pdf>
- [3] Instruction manual for Data Precision 2450 Digital Multimeter
<http://exodus.poly.edu/kurt/manuals/manuals/Other/DATA%20PRECISION%202480,%202480R%20Instruction.pdf>