

Quantum ground state and single- phonon control of a mechanical resonator

A. D. O'Connell, M. Hofheinz, M. Ansmann, Radoslaw C. Bialczak,
M. Lenander, Erik Lucero, M. Neeley,
D. Sank, H. Wang, M. Weides, J. Wenner, John M. Martinis & A. N.
Cleland

Nature 464, 697 (2010)



Science's 2010 Breakthrough of the Year



“This year’s Breakthrough of the Year represents the first time that scientists have demonstrated quantum effects in the motion of a human-made object,” said Adrian Cho, a news writer for Science.

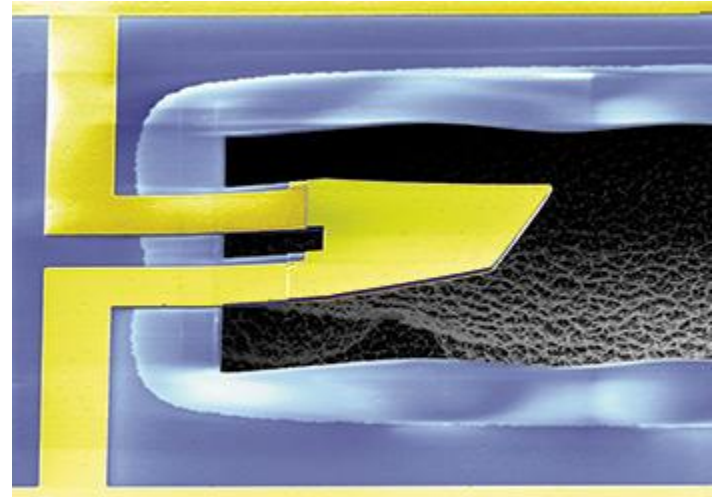

So what did they do?

Coupled a qubit to a harmonic oscillator...well we should all be experts at that right?

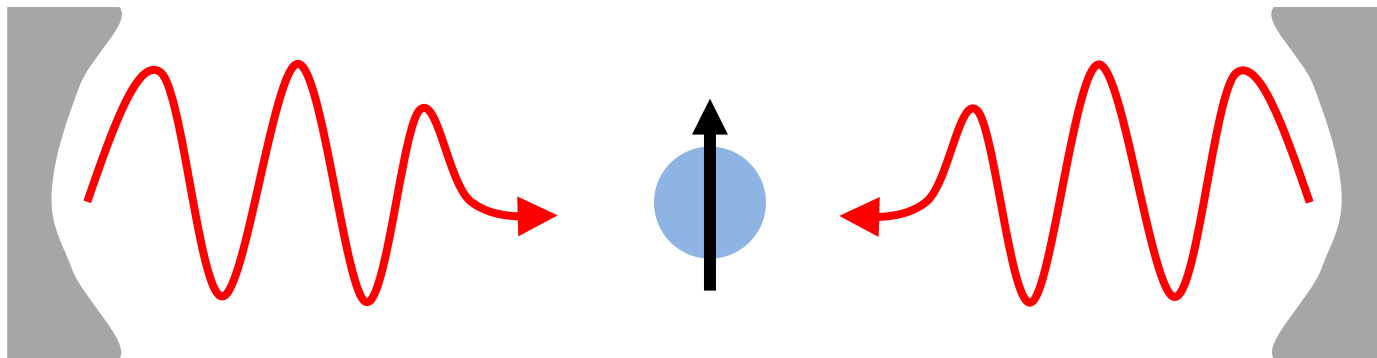

Treat the “resonator” classically:

$$H = \hbar\Delta|e\rangle\langle e| + \frac{\hbar\Omega}{2} (|e\rangle\langle g| + |g\rangle\langle e|) + \frac{\epsilon_0}{2} E^2 + \frac{1}{2\mu_0} B^2$$

Treat the “resonator” quantum mechanically:

$$H = \hbar\omega_0|e\rangle\langle e| + \alpha(|e\rangle\langle g|\hat{a} + |g\rangle\langle e|\hat{a}^\dagger) + \hbar\omega\hat{n}$$

One difference is their two-level system is a superconducting Josephson qubit

In a previous paper they coupled this qubit to a quantized EM mode:
Synthesizing arbitrary quantum states in a superconducting resonator
Nature **459**, 546-549 (28 May 2009)

So what's new?

Now the resonator is a macroscopic object

Conceptually this paper breaks down into two parts



Mechanical resonator

Superconducting
phase qubit

Quantum optics
experiments
demonstrating
resonator is
“quantum”

Mechanical Resonators

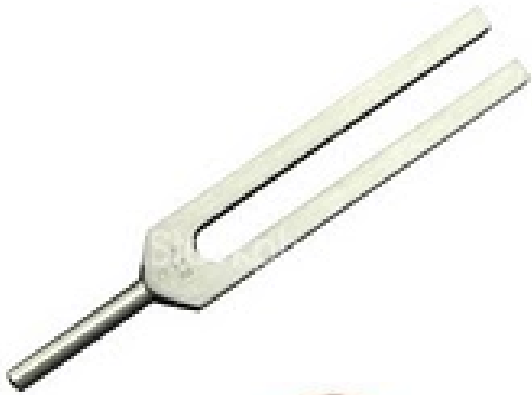

Needs to be high frequency ($T \ll h f$), low loss, able to couple to a qubit

A common “resonator” are the acoustic modes of a crystal

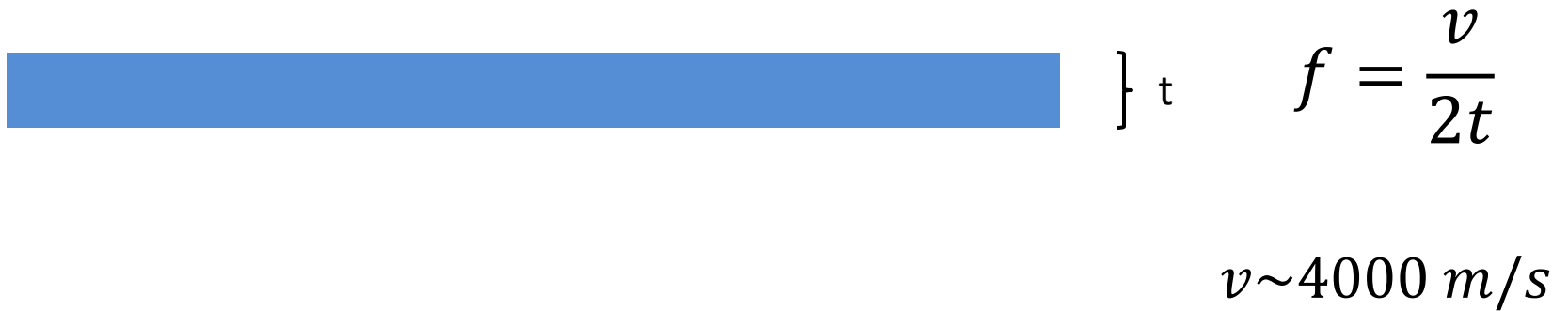

How to couple to a qubit? Piezoelectricity.

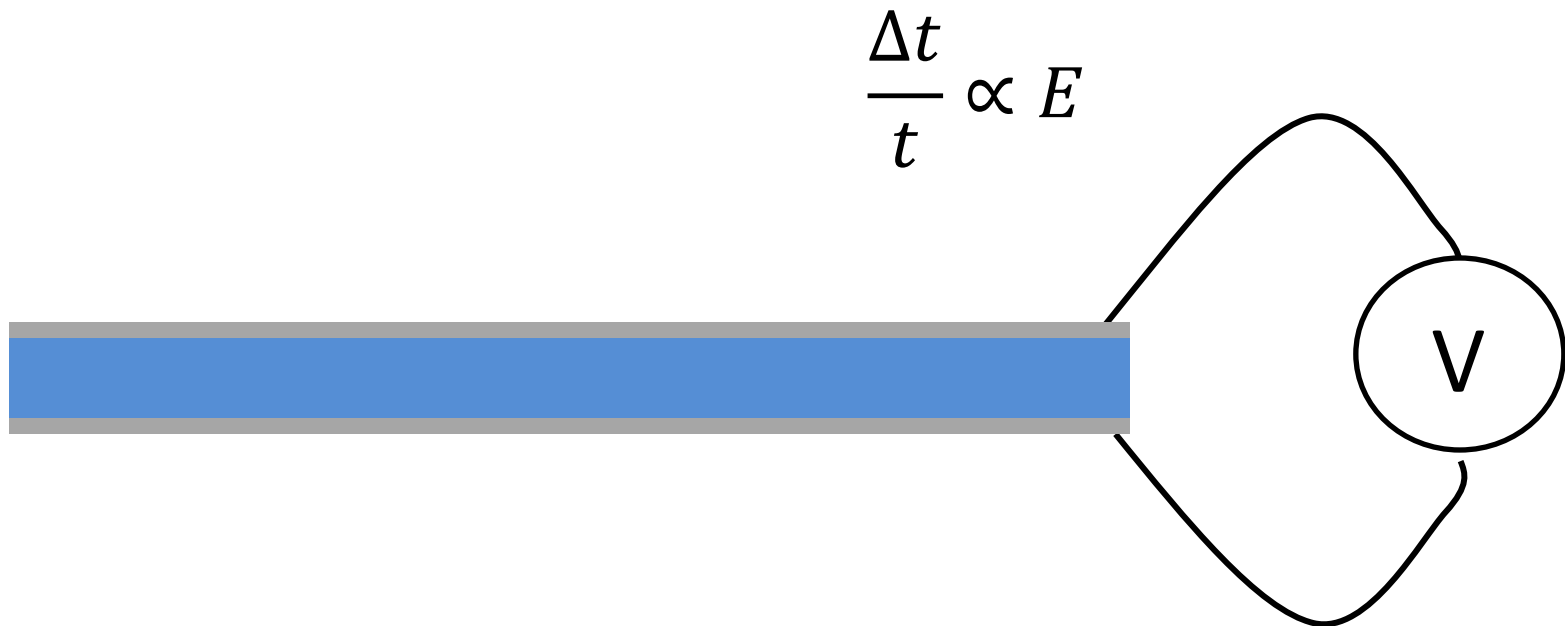

Equivalent Circuit Model

Physical Resonator

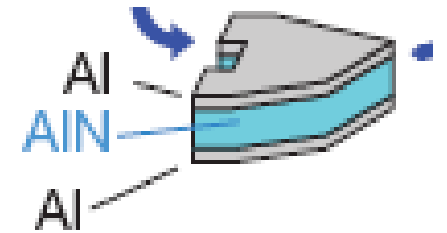
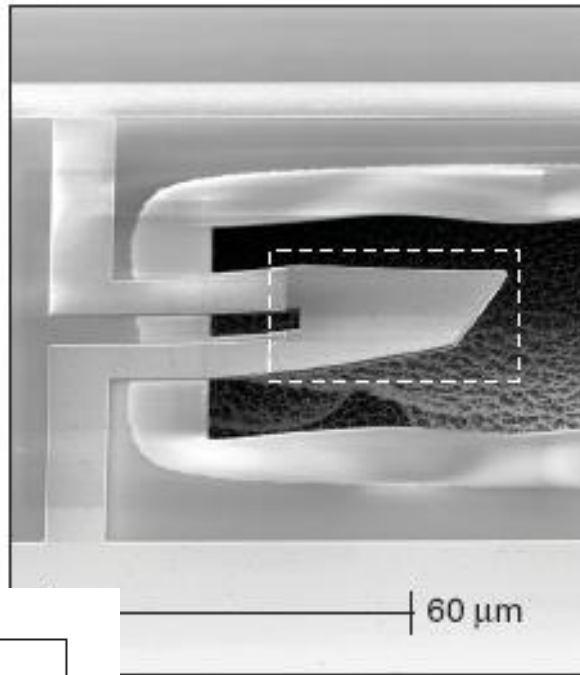
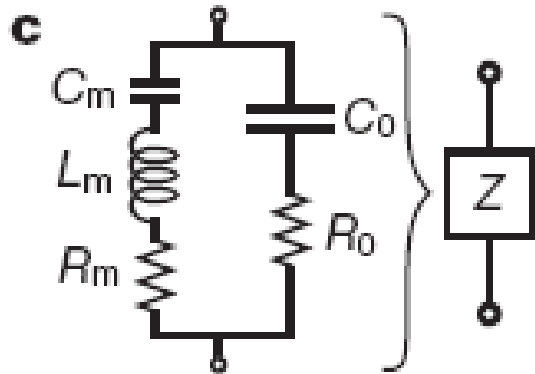

$t = 330 \text{ nm}$

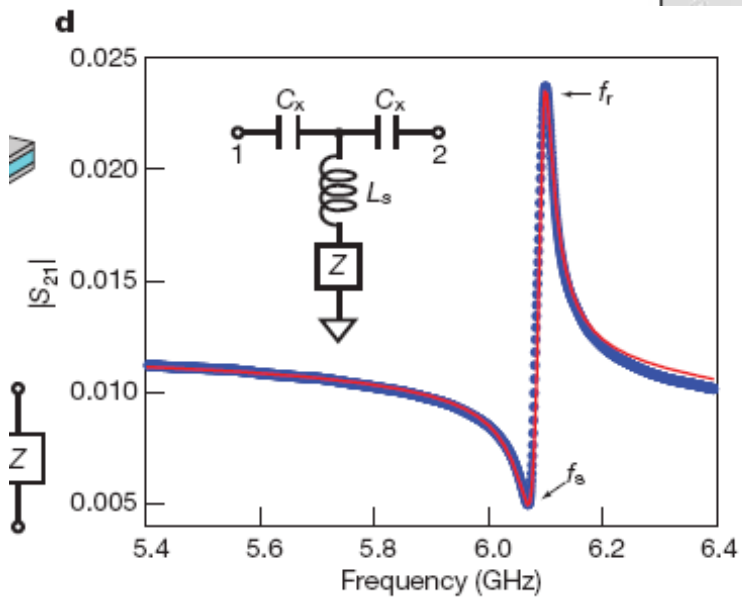

Now we need an electronic qubit...superconducting phase qubit!

First – let's look at the electronic *quantum* resonator

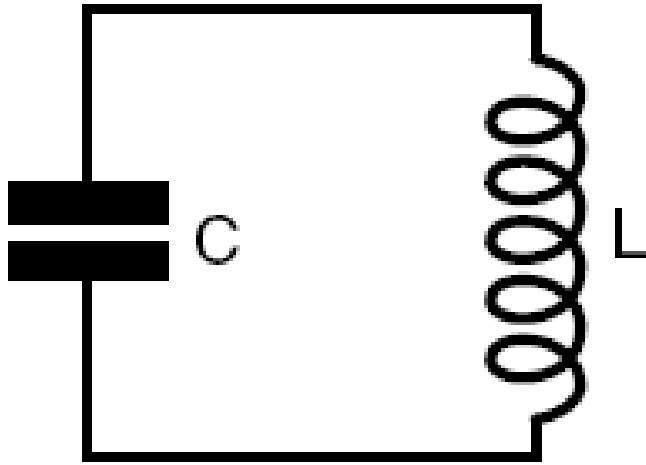

$$H = \frac{1}{2C} Q^2 + \frac{1}{2L} \Phi^2$$

$$[\Phi, Q] = i\hbar$$

Not a good qubit because the energy levels are evenly spaced

Josephson Junction

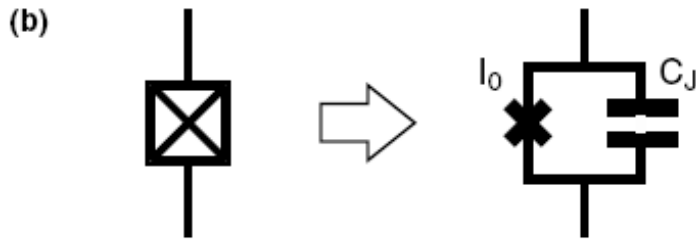
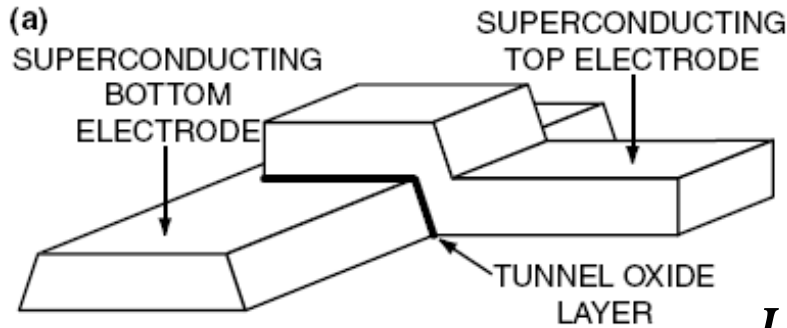

$$H = \frac{1}{2} \left(\frac{E_C}{2e} \right) Q^2 - E_J \cos \left(\frac{2\pi\Phi}{\Phi_0} \right)$$

Non-Linear Inductance

Adding a current bias,

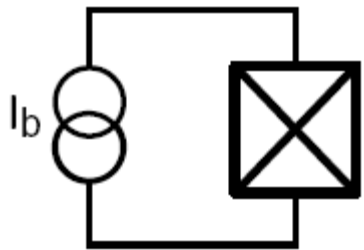

$$H = \frac{1}{2} \left(\frac{E_C}{2e} \right) Q^2 - I\Phi_0\delta - E_J \cos(\delta)$$

$$\frac{2\pi\Phi}{\Phi_0} = \delta$$

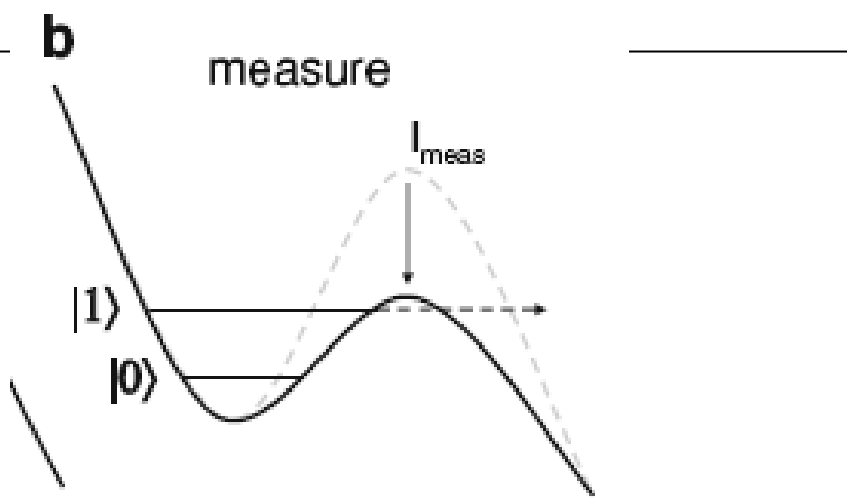
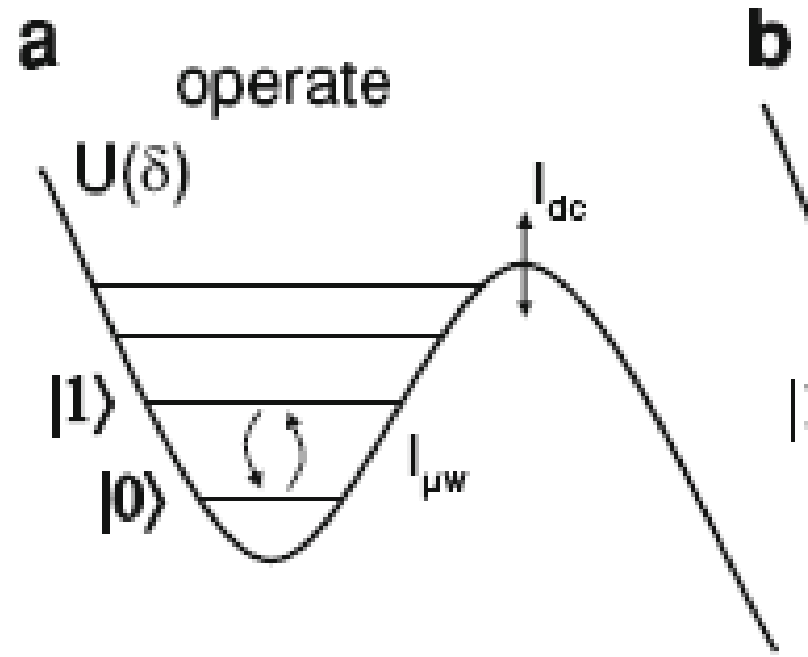
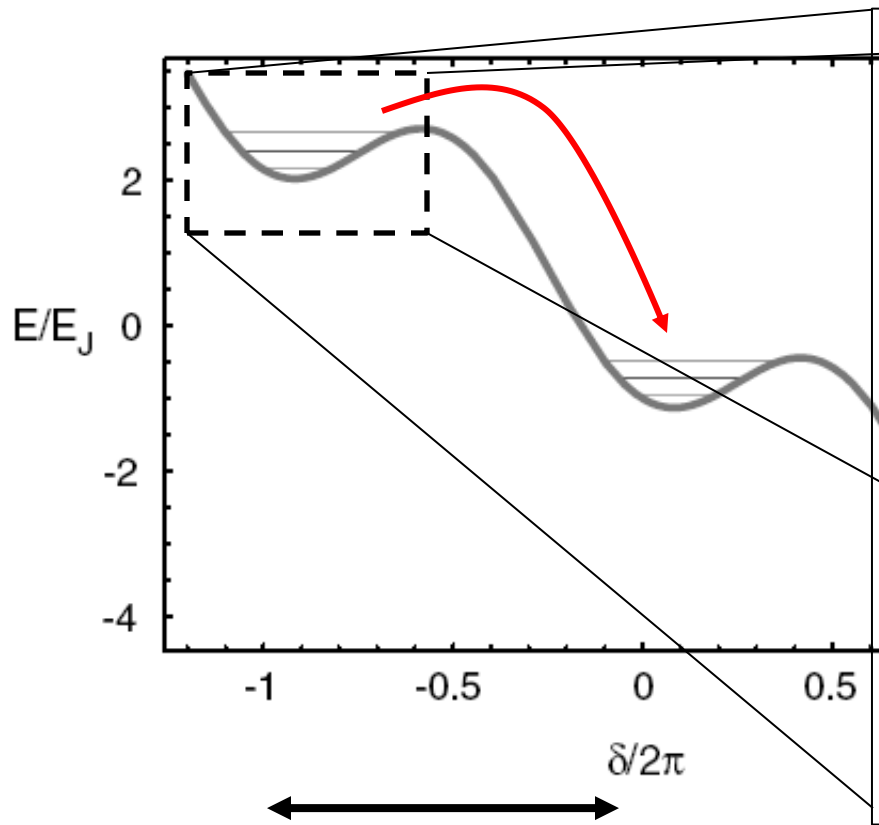

This flux jump can be measured

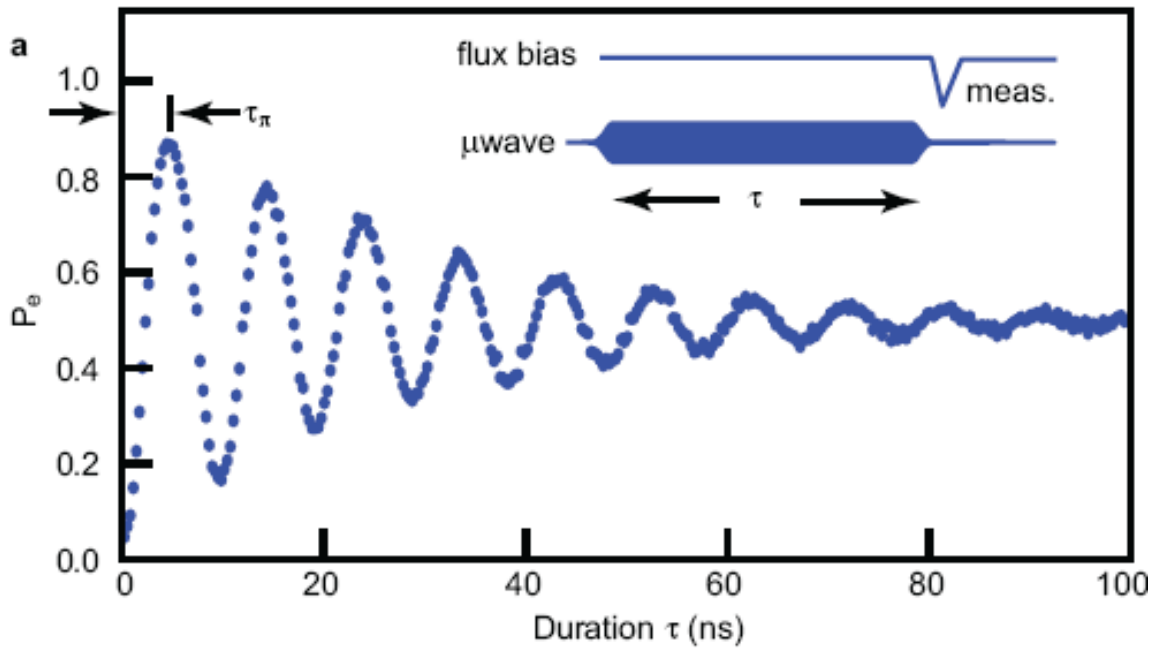

Qubit Rabi oscillations and decay time

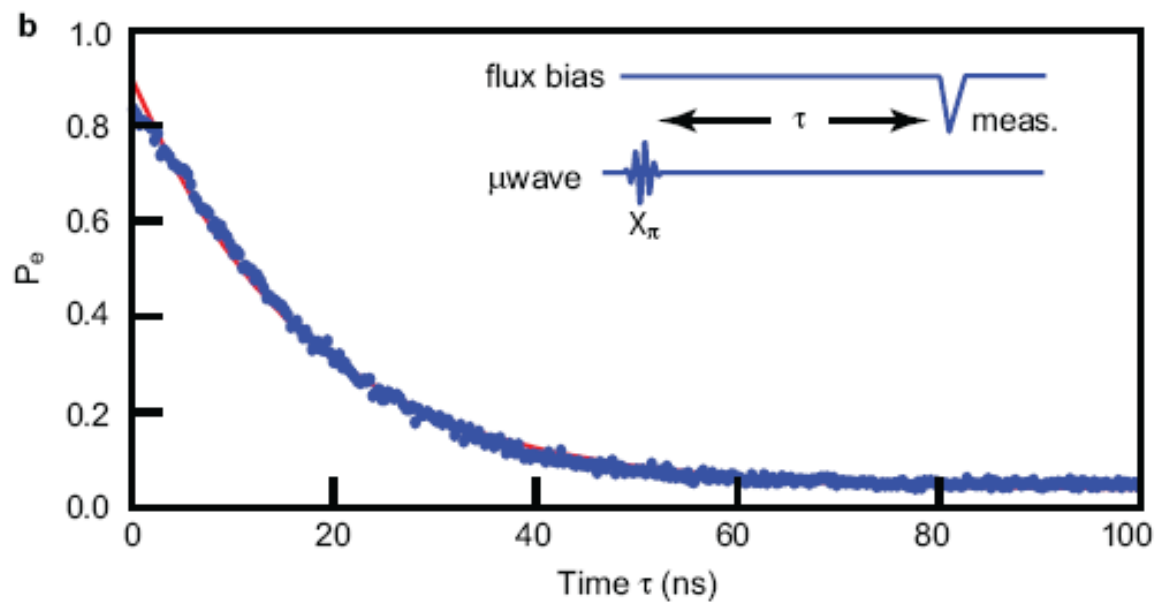

All Together Now

For biasing the qubit and for driving qubit transitions (with microwaves)

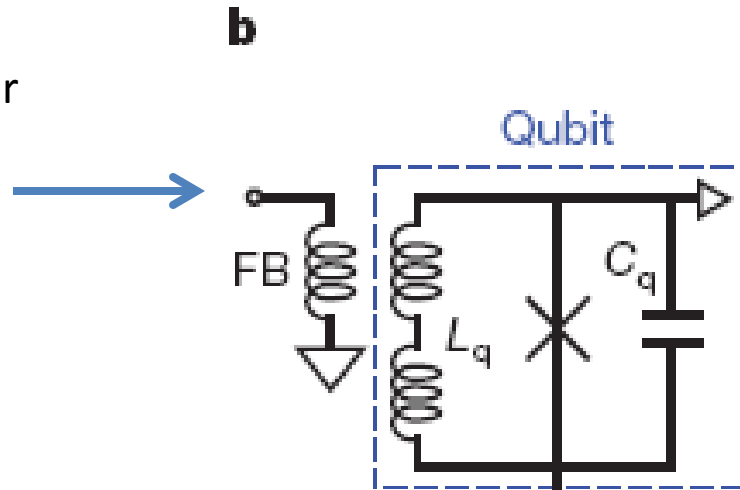

This is like our atom in the cavity

This is like the electric dipole interaction term

This is like the EM field

For driving the resonator

Whole thing is at 25mK
(1GHz ~ 50mK)

Mechanical resonator

“Classical” Test – Can we drive Rabi Oscillations of the Qubit with the Resonator?

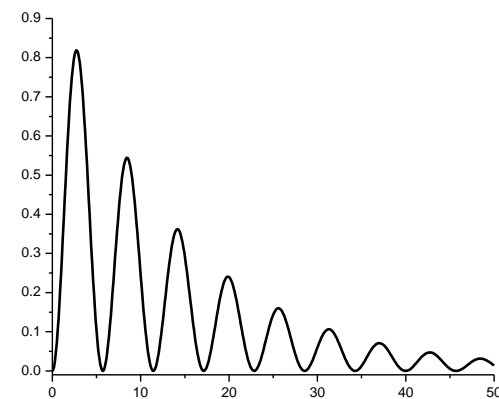
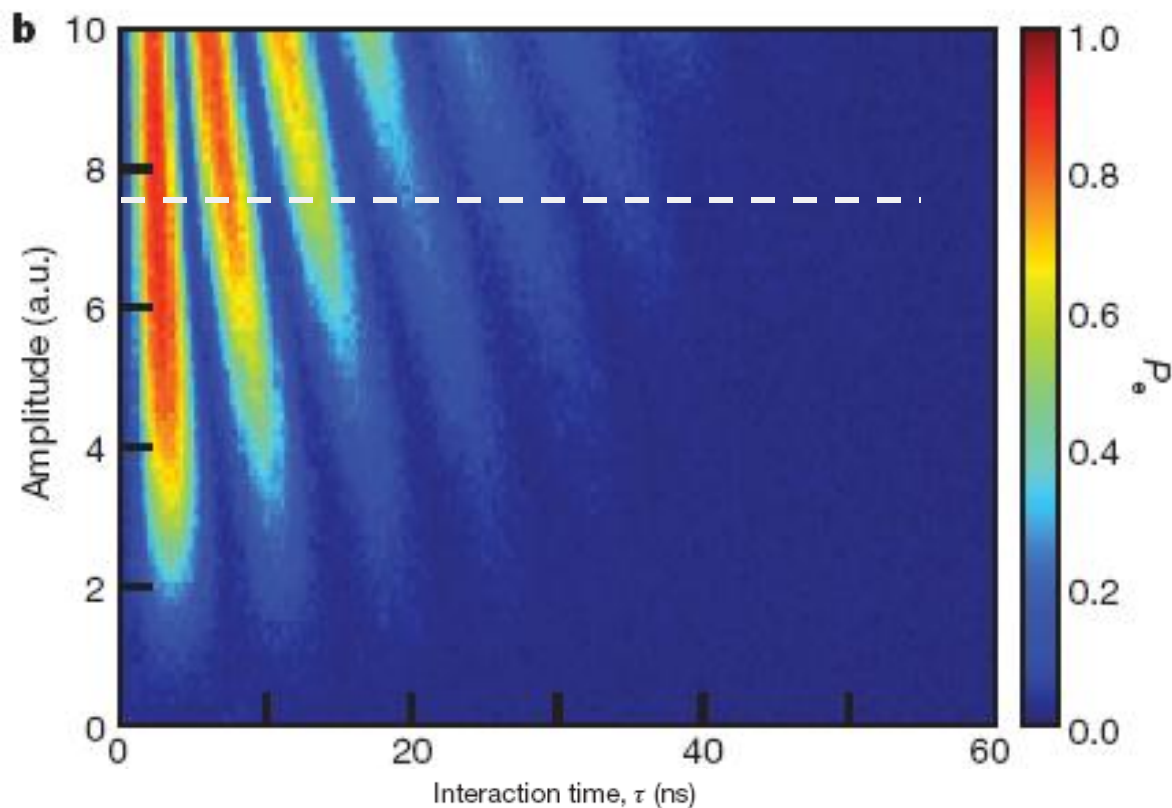
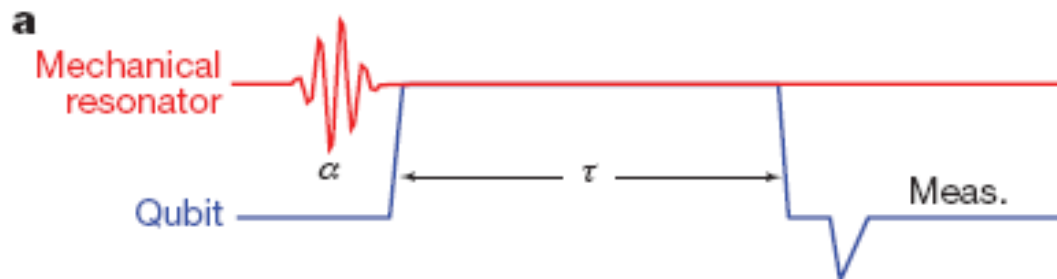

Rabi frequency
increases linearly with
the size of the
resonator kick

Is the Resonator in the Ground State?

Since we know the resonator can drive transitions in the qubit...a lack of qubit transitions would indicate a lack of resonator motion

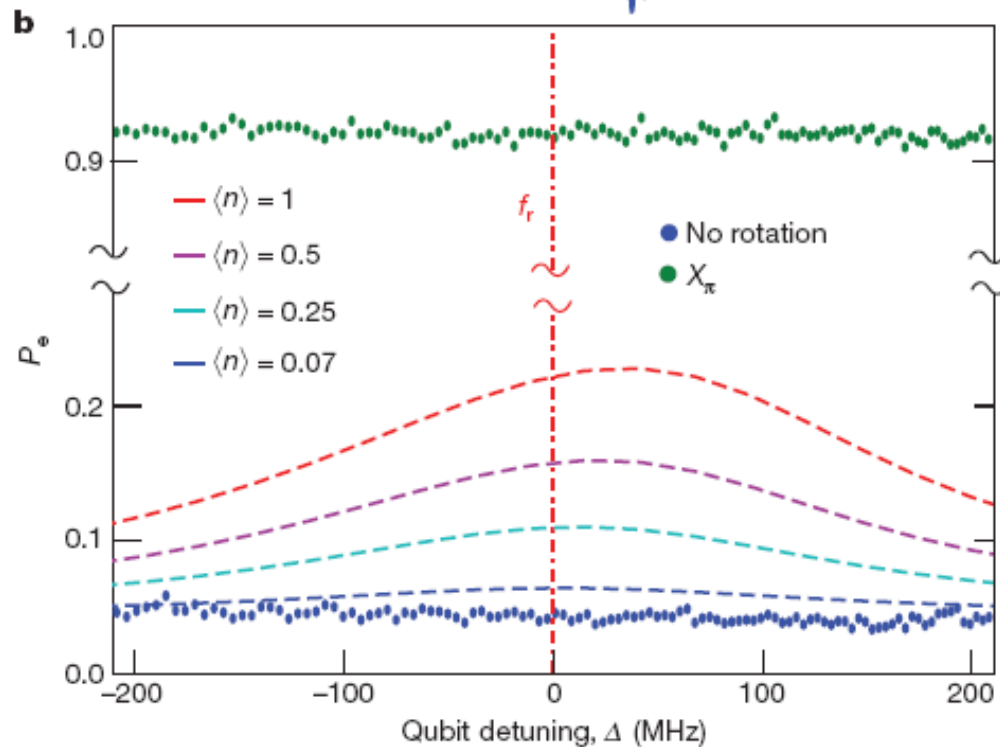
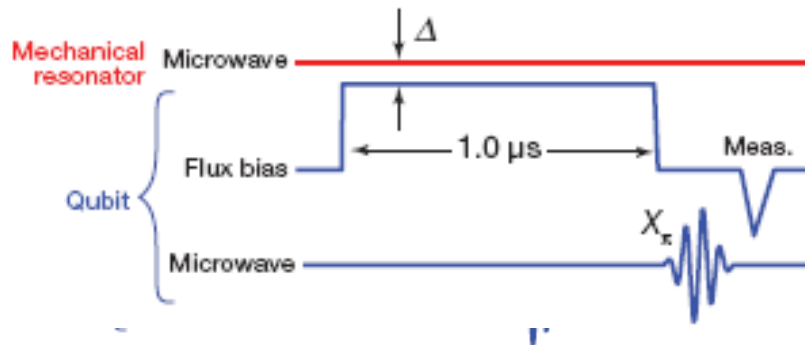

Dashed lines are theoretical curves

Less than 0.07 phonons in the resonator

Do we have strong coupling? Vacuum Rabi Splitting...

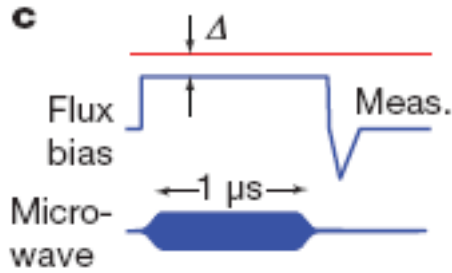

Do an excitation pulse of the qubit system and measure excited population

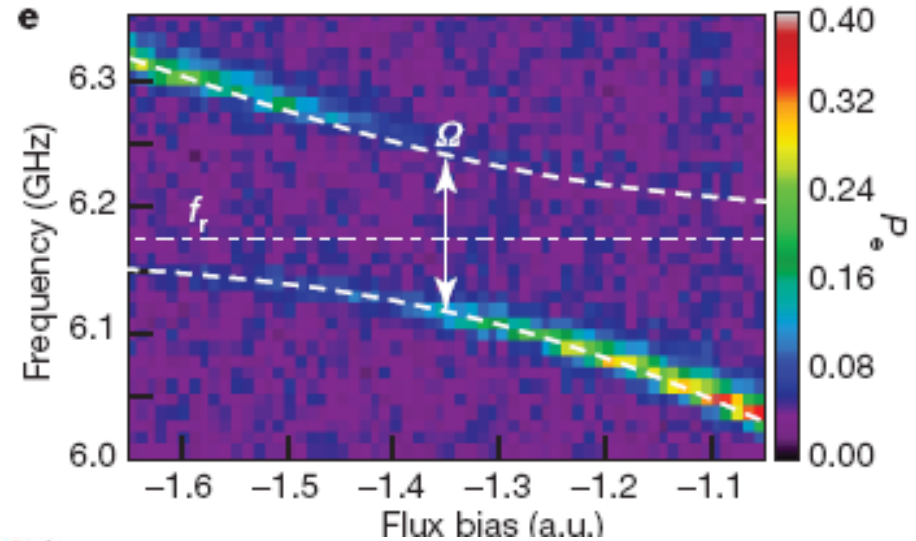
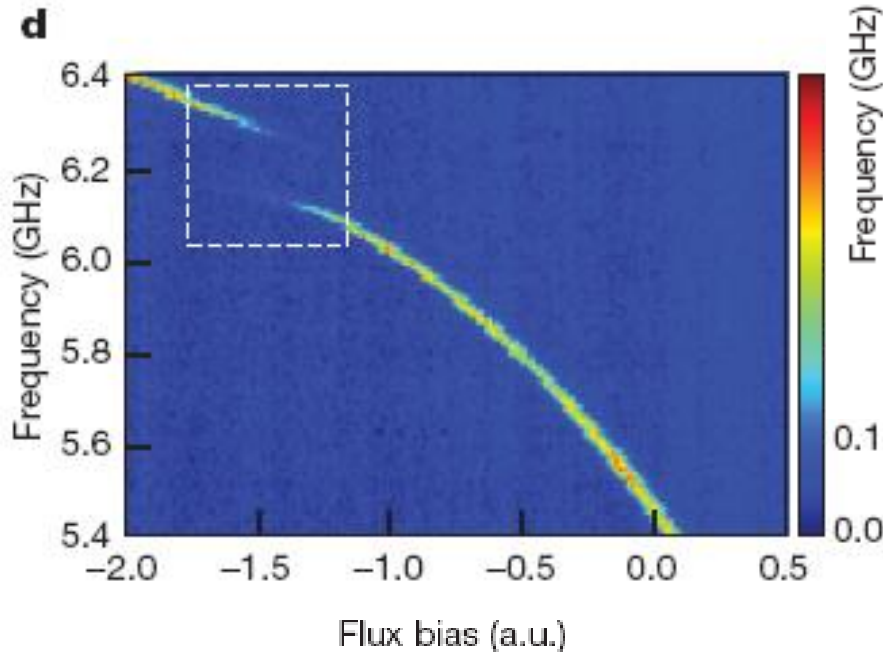

$$\Omega = 124 \text{ MHz}$$

Note: not a proof the resonator is quantum
See eg Nature 454, 315-318 (17 July 2008),
Phys. Rev. Lett. 76, 1800-1803 (1996)

The big result....sharing a single quanta with the resonator

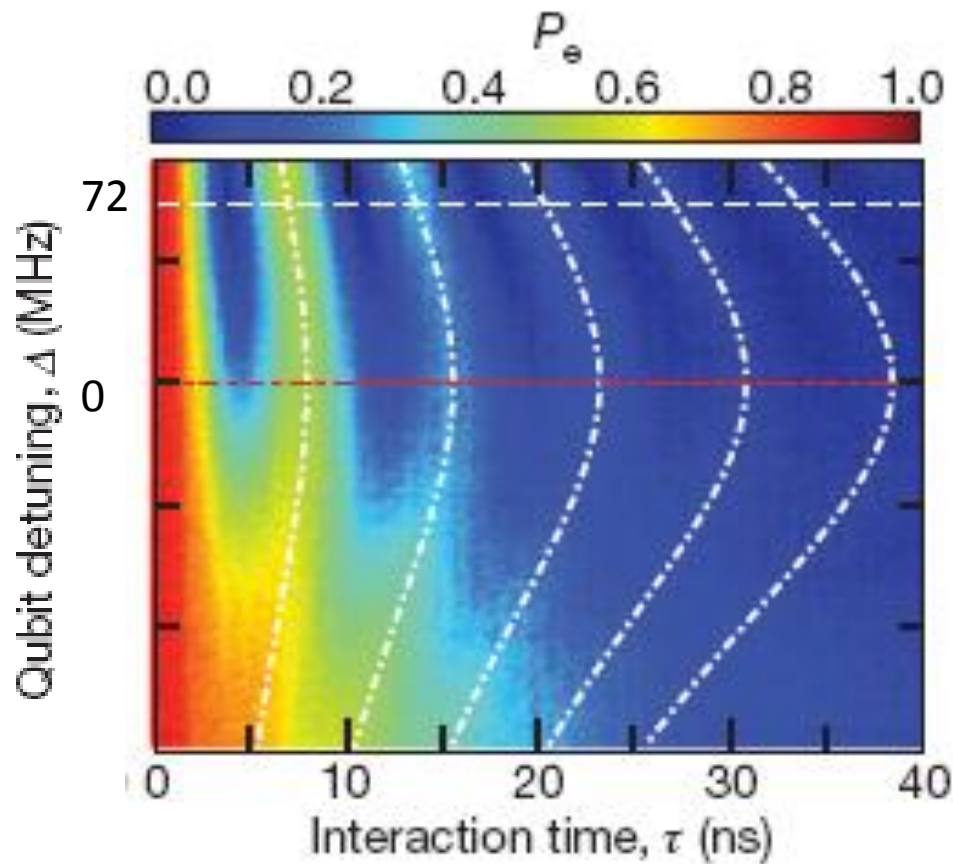
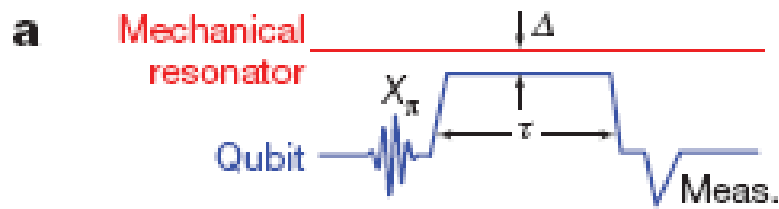

System is entangled here in the state $|g1\rangle + |e0\rangle$

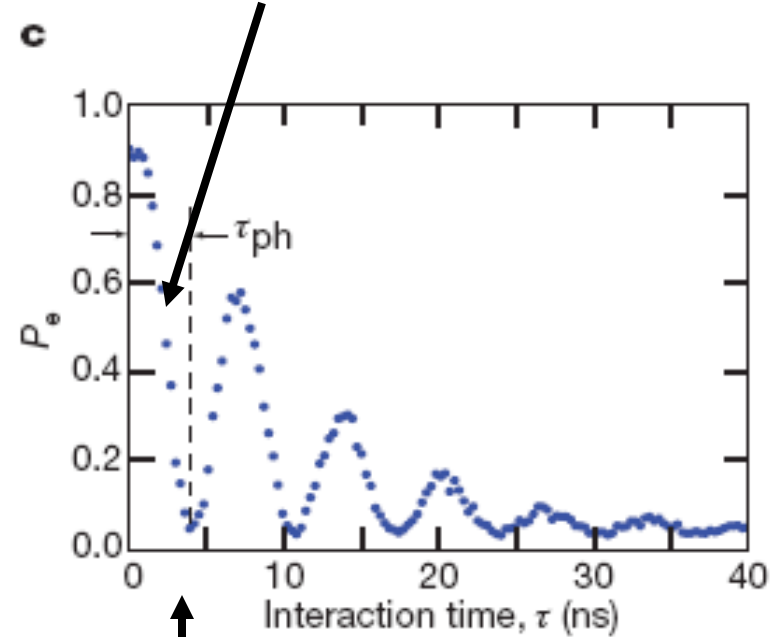

Single quanta in the resonator

$|g1\rangle$

Summary

Coupled a small mechanical “drum” to a superconducting phase qubit

Demonstrated strong coupling between the two systems (faster than decay)

Cooled both systems to the ground state

Huge technical feats

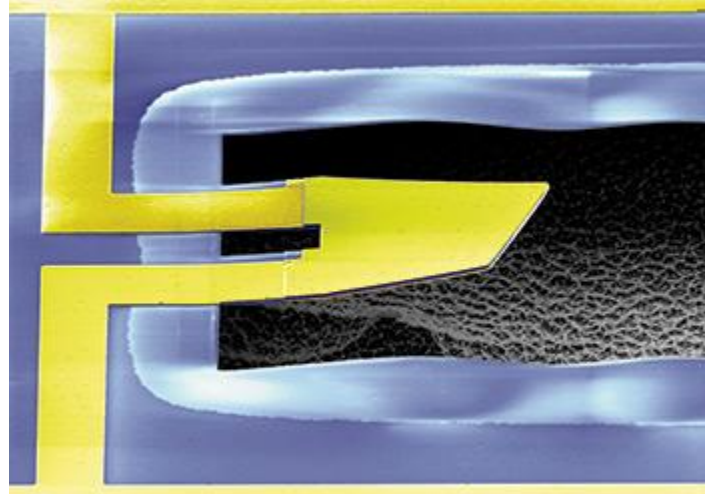

Swapped a single quanta from the qubit to the resonator

On a final note it's interesting to point out that the difference in position of the ground and first excited state is 10^{-16} m, which for the time while hamper true tests of “here and there” quantum superpositions