

NANOKELVIN OF THE NORTH

by S.H. Myrskog, J.K. Fox, and A.M. Steinberg

Fascinating and important new phenomena are often discovered by studying systems under extreme conditions. Such extremes can arise in violent environments, such as the most intense laser beams, highest-temperature plasmas, and highest-energy particle accelerators. However, the opposite end of the spectrum is also often a source for new insights. The study of materials at ultra-cold temperatures led to the discovery of

superconductivity and superfluidity. Experiments at low light levels, where a single photon is detected at a time, reveal some of the most striking effects in quantum mechanics, and appear to promise applications in computing and cryptography.

In the past few years, an exciting new avenue to both fundamental studies and potential applications has been opened up by the lowest temperatures ever observed, temperatures achieved thanks to atomic physics techniques known broadly as laser cooling.

In 1997 the Nobel prize in physics went to three of the physicists who have been among the most influential in developing and elucidating these techniques: Steven Chu, Claude Cohen-Tannoudji and William D. Phillips. The prize was awarded for their work in trapping and laser cooling of atoms to temperatures on the scale of millionths of a degree above absolute zero. Laser cooling, first proposed in 1975 by Hansch and Schawlow^[1] and by Dehmelt and Wineland^[2], makes it possible to achieve these extremely low temperatures within a fraction of a second without any of the familiar but daunting apparatus of low-temperature physics. The cooling and trapping are achieved using low-power lasers similar to those found in laser pointers and CD players, along with simple electromagnets.

The progress toward colder and colder atoms reached a climax in 1995 when the groups of Eric Cornell and Carl Wieman at JILA and Wolfgang Ketterle at MIT

succeeded in producing Bose-Einstein condensates in alkali vapours^[3,4]; they have since been followed by about 20 other groups worldwide. (Information about these groups can be found at the website <http://amo.phy.gasou.edu:80/bec.html>.) In a condensate, the atoms are cooled so far that their wave nature becomes apparent, and the quantum-mechanical uncertainty in their positions causes them to "overlap".

An exciting new avenue to both fundamental studies and potential applications has been opened up by the lowest temperatures ever observed, temperatures achieved thanks to laser cooling.

Combined with the strange implications of quantum indistinguishability, in a sort of reversed counterpart to the Pauli exclusion principle, this overlap causes the trapped alkali atoms to make a phase transition into a state where all the millions of atoms are described by a

single ground-state wave function. While conceptually equivalent to superfluidity in ⁴He and closely related to superconductivity in metals, alkali-atom condensates offer new possibilities for testing fundamental physical theories and for studying the wavelike behaviour of matter. Drawing analogies with optical systems, it is now possible to make an atom laser, a monoenergetic beam of atoms with unprecedented luminosity and coherence. A pulsed atom laser was first demonstrated by Ketterle *et al.* in 1997^[5] and several groups have now demonstrated continuous or quasi-continuous outcoupling^[6]. Atom lasers may have many potential applications, from high-precision measurements to nanometre-scale atom lithography. Recently, the first nonlinear atom-optical effect (the direct analogue of four-wave mixing) was observed^[7].

At the University of Toronto we have employed some of the same techniques to produce what we believe to

S.H. Myrskog (myrskog@physics.utoronto.ca), J.K. Fox (jkfox@physics.utoronto.ca), and A.M. Steinberg (aephraim@physics.utoronto.ca), Physics Department, University of Toronto, Toronto, ON, Canada, M5S 1A7.

be the coldest atoms in Canada. Combining standard laser cooling with a new approach called "delta-kick cooling", we have cooled a sample of Rubidium down to 700 nanoKelvin. At these low temperatures, the atoms have de Broglie wavelengths on the order of a micron, making many new studies of quantum phenomena and "atom optics" accessible. We plan on using these cold atoms to study some of the unresolved questions remaining since the beginning of quantum mechanics, focussing in particular on questions related to the amount of time a tunneling atom spends in the forbidden region^[8]. More information about our plans can be found on our website, <http://helios.physics.utoronto.ca/people/faculty/aephraim.html>.

Several other groups in Canada are also working on laser cooling. At the National Research Council, a group in the Institute of National Measurement Standards is using laser cooling to slow down Cesium atoms and thus increase their storage time in the microwave cavity of an atomic clock. Such techniques have been shown capable of yielding the most accurate clocks in existence, with accuracy at the 10^{-16} level^[9]. Information on this project can be found at <http://www.nrc.ca/inms/annual98/ft.pdf>. At TRIUMF, laser cooling and trapping is being used to store and study radioactive isotopes generated in the ISAC facility^[10]. By studying the beta-decay of trapped ^{38}K and ^{37}K (initially at rest), and observing the recoiling nuclei as well as the beta particles, the researchers will be able to directly observe parity violation, and perform sensitive searches for new particles^[11]; this project is described at http://www.triumf.ca/welcome/trinat_exp.html.

COOLING WITH LASER LIGHT

While the applications of lasers for heating, welding, and cutting are relatively familiar, people are often surprised to learn that lasers are also capable of *cooling*. In order to understand how this is possible it is important to understand what we mean by temperature. In an ideal gas, the temperature is simply a measure of the kinetic energy in the atoms' or molecules' random thermal motion. At room temperature, air molecules zip around at hundreds of metres per second. Using lasers, we can slow certain atoms down to speeds on the order of a centimetre a second, corresponding to millionths (μK) or even billionths (nK) of a degree above absolute zero.

When light is absorbed by matter, the optical energy can be converted to heat, increasing the temperature. In the case of isolated atoms, this conversion into random motion occurs through the process of spontaneous emission; after emitting a photon, the atom recoils in a random direction. However, the *absorption* of light also imparts momentum to the atom, leading to the well-known effect of radiation pressure. The photon momentum of $hk (=h/\lambda)$ corresponds to a velocity change of 6 mm/s for a Rubidium atom interacting with a 780 nm photon. A Rubidium atom illuminated with milliwatts of near-resonant light may scatter millions of photons per second, experiencing accelerations as large as 10^5 m/s^2 . The principle of laser cooling is to harness these huge accelerations, and constantly provide a viscous force opposing each atom's motion. This is accomplished by a careful tuning and alignment of a number of laser beams.

A typical laser cooling apparatus consists of a vacuum chamber where both trapping and cooling occur, three

pairs of counter-propagating laser beams, and a set of magnetic field coils, as sketched in Figure 1. In our lab, the interaction region is contained within a small glass cell pumped down to a vacuum pressure of about 10^{-8} Torr. Laser beams are

directed into the interaction region along each co-ordinate axis. A pair of magnetic field coils is placed around the chamber and used to create a quadrupole field distribution with a strong gradient near the centre of the vacuum chamber. The laser beams serve to cool the atoms, and when combined with the magnetic field they simultaneously trap

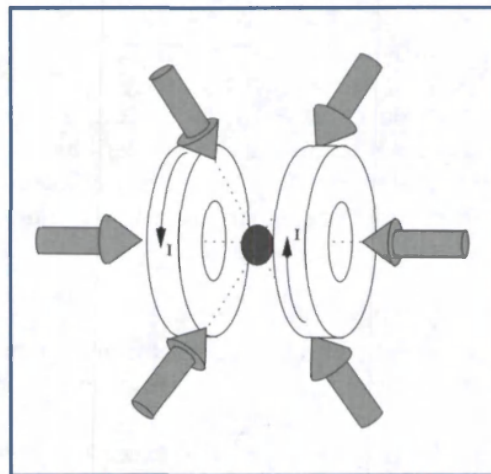

Fig. 1 A schematic view of a typical laser-cooling setup. Along each co-ordinate axis there is a pair of counter-propagating laser beams. A pair of anti-Helmholtz coils is placed along one axis to provide spatial trapping of the atoms.

hundreds of millions of atoms in a millimetre-sized cloud. A picture of the apparatus in our lab is shown in Figure 2.

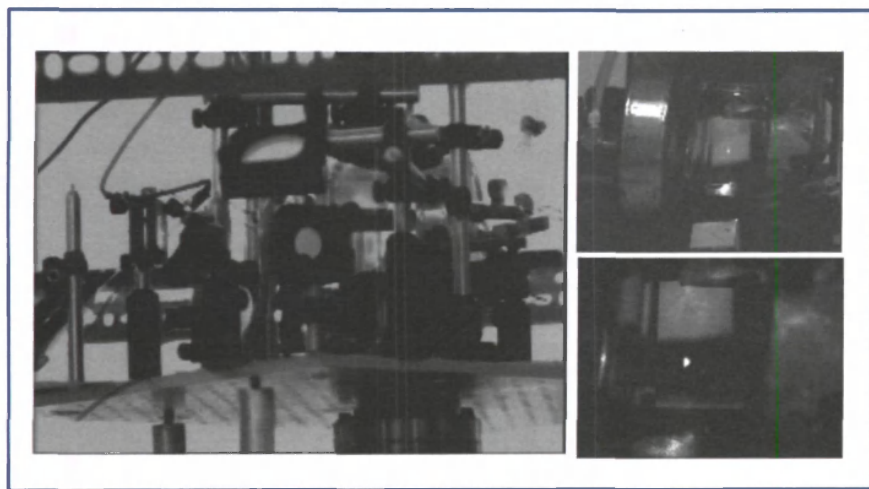

Fig. 2 The experimental apparatus in place at the University of Toronto. The trapping region is located within a glass cell partially obscured by the optical mounts in the foreground. Three pairs of one-inch-wide beams intersect in the centre of the cell. The magnetic field coils are located to the left and the right of the cell. The inserts on the right show progressive close-ups where the trapping chamber can be seen along with a fluorescing cloud of trapped atoms.

The apparatus shown provides trapping and cooling in all three directions, but the cooling process is easiest to understand in one dimension. Consider a two-level atom which has a laser beam incident on it. The absorption of a photon from the beam will change the momentum of the atom by $\hbar k$ in the direction of the photon that was absorbed. Having absorbed a photon, the atom must then re-emit the energy through spontaneous emission. The spontaneously emitted photon is emitted in a random direction, again changing the momentum of the atom by the same magnitude, but in a different direction. The absorption of N photons from a single laser beam results in momentum change of $N\hbar k$. Since the spontaneously emitted photons are emitted in random directions, their contributions average out to zero.

The trick to cooling is to use two counter-propagating lasers, and to arrange matters such that an atom moving in a given direction will always feel a force opposing its motion. That is, the atom must preferentially absorb oncoming photons rather than those travelling along with it. This is possible thanks to the Doppler shift, which may shift the relative frequencies of two laser beams in opposite directions,

as shown in Figure 3. In the reference frame of an atom moving to the right, a laser beam travelling to the left will be Doppler shifted to a higher frequency while a beam travelling to the right will be shifted to a lower frequency. If both beams are tuned slightly below resonance, the blue-shifted photons are more likely to be scattered by the atom than the red-shifted photons, and this has the desired effect. The atom will preferentially absorb photons from the beam opposing its motion, thereby decreasing its velocity. In a 3D setup the atom experiences a viscous force in any direction it attempts to travel. The process has earned the name optical molasses due to this viscous force.

The ultimate temperature this process can yield is limited by the trade-off between the viscous cooling force and the heating due to spontaneous emission. Although when a photon is spontaneously emitted and the atom recoils in a random direction, $\langle \vec{\Delta p} \rangle = 0$, the mean squared

momentum change $\langle |\vec{\Delta p}|^2 \rangle$ is nonzero, and this tends to raise the temperature. The original proposal of "Doppler molasses" predicted a minimum temperature related to the resonance linewidth of the atomic transition. This so-called Doppler temperature is typically on the order of several hundred microKelvin. But when the first careful temperature measurements of optical molasses were accomplished, experimentalists were shocked to find a violation of Murphy's Law: Experiment worked much better than theory and the temperatures of the atoms were

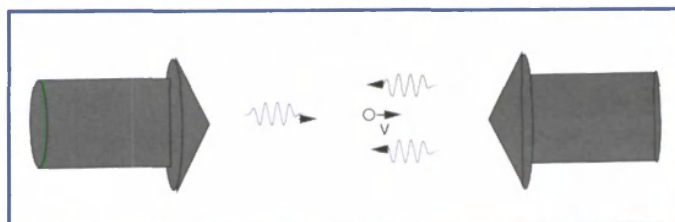

Fig. 3 An atom travelling to the right with two red-detuned beams incident upon it in opposite directions. The left-going beam is Doppler shifted to a higher frequency, closer to resonance, while the right-going beam is shifted to a lower frequency. The atom is then more likely to scatter photons from the left-going beam, reducing the velocity of the atom.

discovered to be about a factor of 10 colder than expected^[12]. One clue which helped lead to an explanation of these effects was the strong dependence of final temperature on laser polarisation, implying that it was necessary to include the angular momentum of the atoms in the theory. By taking into account the full internal structure of the atoms it was soon recognized that temperatures as low as several microKelvin were possible, limited only by the momentum of the last photon scattered during the cooling process^[13]. The interference between two counter-propagating laser beams may produce an optical field whose polarisation vector varies as a function of position. In the so-called lin-perp-lin configuration, two orthogonal linearly polarised beams create a "polarisation gradient" which can be described as two standing waves out of phase with one another, one composed of right-hand circular light and the other of left-hand circular light. Due to the interaction of the atom's angular momentum with the polarised light, each Zeeman sublevel of the atomic ground state experiences a different potential composed of a series of hills and valleys. Under the right circumstances, optical pumping can set up a situation in which atoms spend most of their time climbing these potential hills (and consequently losing kinetic energy) — once the atom reaches the top of a hill, it is optically pumped to a different ground state, on a different potential curve, which is suddenly down in a valley again. The process of repeatedly climbing hills without descending is termed "Sisyphus cooling" by analogy with the Greek myth of Sisyphus, who was condemned to spend eternity rolling a boulder up a hill from which it immediately returned to the bottom, where he started all over again. The atoms keep losing energy until they no longer have enough energy to climb any more hills. This means that one more counterintuitive effect arises — to reach the lowest temperatures, one must actually use weaker laser beams, so that the hills are not too high. In this way, one can circumvent the Doppler cooling limit, and continue cooling until the atom has only a few photon momenta, and travels a few centimetres per second.

THE MAGNETO-OPTICAL TRAP

Although optical molasses is capable of cooling a gas of atoms, the two counter-propagating laser beams create no preferred position, and therefore the atoms are not trapped. Buffeted by the laser beams, they slowly diffuse out of the interaction region. To

spatially trap the atoms requires the addition of a position-dependent force. One way to accomplish this is to use the interaction of the polarised atoms with a magnetic field. If the current in one of a Helmholtz pair of magnet coils is reversed, the fields created by the two coils cancel out at one special point. The resulting quadrupole field $\vec{B} \approx 2B'z\hat{z} - B'x\hat{x} - B'y\hat{y}$ vanishes only at the origin, causing atoms at this point to behave differently from atoms elsewhere.

As atoms move away from the origin, they experience a growing Zeeman shift, changing the energies of their magnetic sublevels. Some levels are shifted closer into resonance with the red-detuned laser beams, and others further away. By a judicious choice of laser polarisation, one can ensure that atoms which stray from the centre will preferentially absorb photons moving back towards the origin. Thus in addition to the velocity-damping accomplished thanks to the Doppler shifts, a spatial restoring force is created with the help of the Zeeman shift. Depending upon the strength of the magnetic fields, the number of atoms, and other parameters, the trapped atom cloud can range in size from over a centimetre to only tens of microns; the cloud in Figure 2 is on the order of a millimetre in diameter.

Having cooled and trapped atoms, one requires a method of measuring the resulting temperature. Obviously, no standard thermometer can be brought into contact with the few million atoms floating inside a vacuum chamber to measure their temperature. The most common temperature-measurement techniques rely on the fact that by temperature, we really mean rms momentum. The measurement is performed by releasing the atom cloud for a fixed time t , and subsequently taking a time-of-flight picture of the expanded cloud. The picture is obtained by applying a

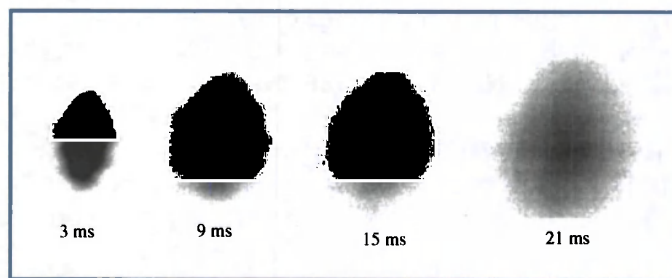

Fig. 4 A series of atomic cloud images at different times after release. At long times the size of the cloud grows at a rate proportional to the thermal velocity.

short pulse of light and observing the "shadow" of the cloud on a CCD camera, providing information on the cloud size and the number of atoms contained. If a sequence of images is acquired, the free ballistic expansion of the cloud may be observed as in Figure 4. By graphing the radius as a function of time, the rms velocity and hence the temperature may be extracted (see Figure 5).

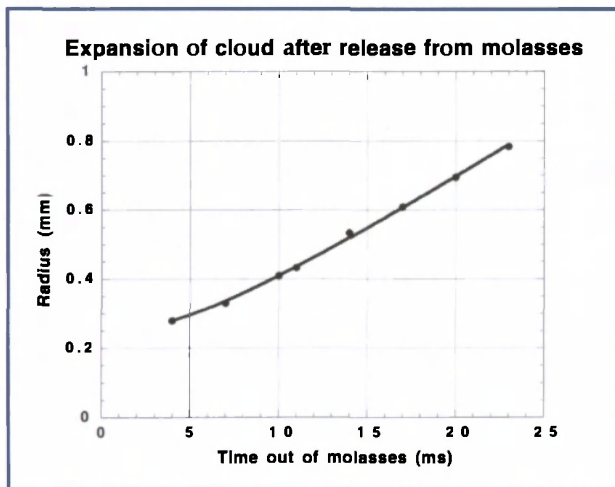

Fig. 5 A graph showing the rms size of the atom cloud as a function of the time after release from the trap. The solid line is a fit to the data points (circles), which yields a velocity of 3 cm/s, corresponding to $9\mu\text{K}$.

"DELTA-KICK" COOLING

Although the Sisyphus molasses can cool atoms down to several microKelvin, this still leaves them with de Broglie wavelengths significantly shorter than an optical wavelength, and too short for many of the most interesting applications of laser cooling. There are a number of techniques for moving beyond this "recoil limit" and achieving lower temperatures, and we have been studying one known as "delta-kick cooling". The quadrupole magnetic fields which along with the cooling laser create the magneto-optical trap (MOT) can also be used to further cool the atoms. If the laser beams are turned off, the magnetic moments of the atoms adiabatically follow the local magnetic field as the atoms move about. Thus each atom sees a potential proportional to the *magnitude* of the local magnetic field, which has the form

$$|\vec{B}| = B' \sqrt{4z^2 + x^2 + y^2} \quad (1)$$

near the centre of the coil pair, where z is the coils' symmetry axis. The magnitude and the sign of the potential depend on the Zeeman sublevel of the atoms, but for a certain fraction of the atoms, the magnetic field provides a conservative restoring force (but no cooling); this force is the origin of the magnetic trap used in Bose condensation experiments.

In our experiment, we shut off the laser beams and magnetic fields to allow the atoms to expand ballistically. As they expand, a correlation develops between position and momentum: the fast atoms are far from the origin, while the slow atoms are near. Applying a brief current pulse to the coils exerts a quick force, or impulse, on the atoms toward the centre of the trap. If the strength of this impulse is chosen properly, it can be used to counteract the motion of the atoms away from the origin. For example, by changing the sign of the current in one of the coils, we can produce a quadratically varying magnetic field, and hence a quadratic potential. Like any harmonic oscillator, this will exert a greater force on an atom the further the atom is from the centre. But the atoms far from the centre are precisely those atoms with the highest velocities. For this reason, a "harmonic kick" can in essence bring all the atoms close to zero velocity. This is a variant of a proposal by Ammann and Christensen^[14], which they termed delta-kick cooling since they considered the limit in which the impulse is delivered in an infinitesimally

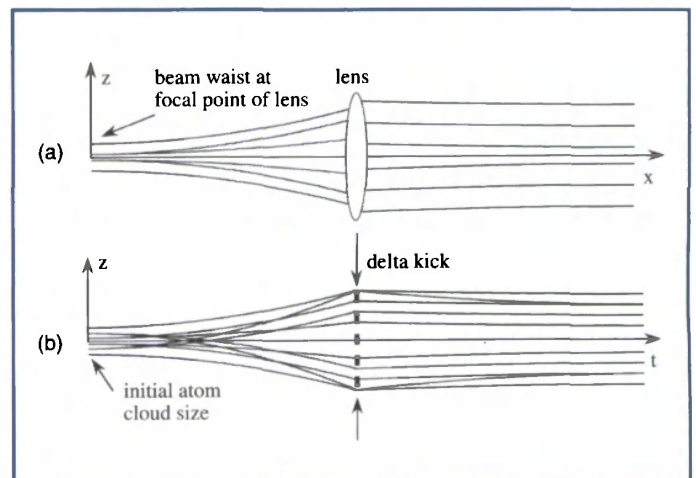

Fig. 6 (a): A light beam's waist is located at the focal point of the lens. On passing through the lens, the light becomes collimated, that is, no longer expanding in the z direction. (b): A cloud of atoms is expanding in the z direction with time. After the delta kick, the atoms' expansion is stopped, and the atoms have been cooled.

short time. As it happens, even for non-harmonic kicks such as the one supplied by a quadrupole field, a significant amount of cooling can still be achieved.

An analogy to gaussian optics can help understand the effect of a delta kick. Consider the following: a source of light is located at the focal point of a lens. The light that enters the lens will be collimated along the x direction as shown in Figure 6. If the power of the lens is made stronger without moving the light source, then the light that enters the lens will come to a focus and then start to expand again, as in Figure 7. On the other hand, if the power is decreased, the beam will continue to expand. The delta kick can be considered as a lens for a cloud of atoms. Instead of a beam of light expanding and then being collimated along the x axis, the expanding cloud of atoms is collimated in time, meaning that the cloud radius remains constant as a function of time.

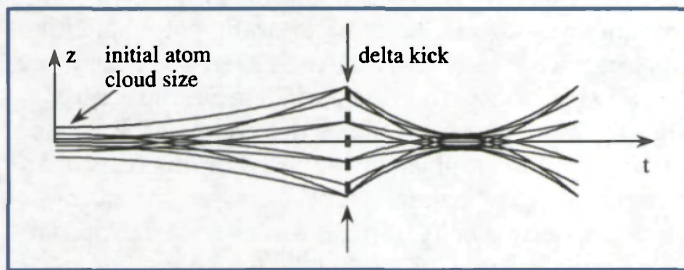

Fig. 7 A cloud of atoms which were kicked too hard. After going through a focus, the atoms now have a greater velocity, thus a higher temperature

In our setup, the symmetry axis z of the quadrupole coils is oriented along the horizontal. Because of gravity, the atoms fall a small distance in y , the vertical direction, between the time the MOT is turned off and the application of the current pulse for the delta-kick. The quadrupole potential forms a distorted cone, whose gradient in the z direction is twice as large as in the x and y directions. As the atoms move away from the origin along y , the potential they see in the $x-z$ plane becomes a parabolic conic section, as can be seen from a Taylor expansion of Eq. (1) for $y \gg z$. As in an ideal harmonic kick, the atoms feel a force (at least along the z direction) proportional to their distance from the origin: $F_z = -Kz$.

After free expansion lasting for a time t_f , the position of each individual atom in the cloud is given by $z = z_0 + v_z t_f$, where v_z is the velocity of the atom in the z direction and z_0 is the initial position of the atom. Thus an atom's velocity in the z direction after a time

$t_f \gg z_0/v_z$ is equal to $v_z = (-z_0)/t_f \approx -z/t_f$, and, like the strength of the delta kick, is essentially proportional to the distance from the origin. As a result, when the delta kick is applied to the cloud, the fastest (hottest) atoms are, appropriately, given the greatest impulse. If the impulse is matched to an atom's momentum, then the atom's motion should be stopped. If the magnetic coils are pulsed for a time δt , then a change in momentum of $\Delta p_z = F_z \delta t = -Kz \delta t$ is imparted to each atom. By adjusting the strength of the kick such that $K \delta t = m/t_f$, we can bring all the atoms nearly to rest in the z -direction simultaneously, thus lowering the one-dimensional temperature. (Due to the pronounced anisotropy of the potential, the temperature in the x and y directions is not greatly affected.) Figure 8 shows the effect of a one-dimensional harmonic force on atoms expanding isotropically from the origin.

The factor by which a cloud of atoms can be cooled is limited by the fact that all the atoms do not have the same initial position z_0 . If they did, then their velocities would be perfectly correlated with their positions, and we could apply a kick which would be appropriate for each velocity class of atoms. Since this is not the case, we have atoms at different velocities with equal z components, so when we apply the kick, some atoms get kicked too strongly, while

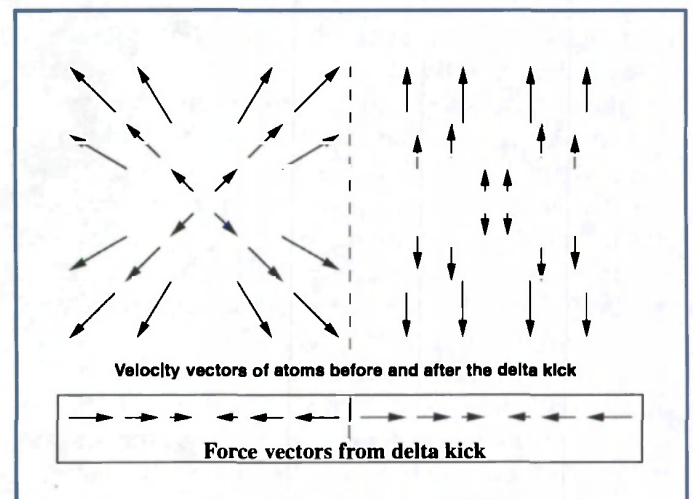

Fig. 8 Atoms in the expanding cloud have velocity components in all directions (the z direction is horizontal here). After an ideal delta kick, whose strength is shown in the bottom section for different values of z , the z component of each atom's motion is stopped while the other velocity components remain virtually unchanged.

others are not kicked strongly enough. Relative to the ideal case, a typical atom starting a distance r from the origin will receive an excess momentum kick equal to $-Kr\delta$. Since the ideal kick strength

$$K\delta t = m / t_f,$$

we see that we can mitigate this effect by simply using the longest practical free-expansion time t_f . In other words, the longer we wait before applying the kick, the more strongly correlated the atoms' positions and velocities become. As the momentum kick experienced by an atom is proportional to z , the ratio of the excess kick (i.e., beyond the value necessary to stop the atom) to the intended kick is equal to the ratio of the uncertain initial position r to the expected final position $\sim v_{rms}t_f$. Since the intended kick alters the momentum just enough to cancel out the initial velocity $\approx v_{rms}$, we are left with a final velocity on the order of $\frac{r}{v_{rms}t_f} v_{rms}$. In other words, if the atom

cloud is allowed to expand by a factor of

$$N \left(\approx r / v_{rms}t_f \right)$$

before the kick is applied, the rms momentum can be reduced by a factor of N , and the temperature by a factor of N^2 . In this sense, delta-kick cooling is the moral equivalent of adiabatic expansion, but the requirements on the speed of the process are not as stringent.

After application of the delta kick, we allow the atoms to resume their expansion, and we acquire images of the atom cloud every 3 ms in order to measure the final temperature. Figure 9 shows images of atoms given a delta kick about 10 ms after being released from optical molasses. It can be seen from the figure that not all atoms are cooled by the kick. This is because the cloud of atoms contains different magnetic sublevels, which are affected differently. We are studying ^{85}Rb atoms in a ground hyperfine state with total angular momentum $F = 3$. The atoms

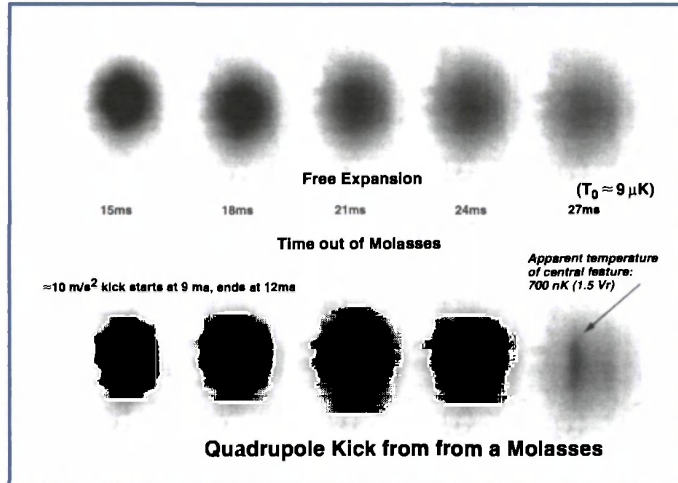

Fig. 9 Result of delta kick on an atom cloud. There is a high density of atoms around $z = 0$ appearing as a thin dark stripe. These are the atoms whose velocities have been diminished by the kick, so at later times, they are still near the origin. Atoms unaffected by the kick expand as they would during normal free expansion.

with the largest magnetic quantum number, $m_F = 3$, feel the greatest force and form the thin stripe visible in the figure. Atoms with $m_F = 0, 1, 2$ are not "kicked" as hard; atoms with $m_F = -1, -2, -3$ are actually accelerated away from the origin. These components taken as a whole show no sign of cooling, and constitute the larger, more rapidly expanding cloud in Figure 9. Related effects have been studied by Maréchal *et al.*, who use a magnetic field gradient to isolate the different spin states of a freely-falling atom cloud^[15].

We analyse these images using the time-of-flight method to determine the final temperature. Figure 10 shows the size of the atom cloud as a function of time, before and after the kick. It also shows the width of the cold, narrow stripe on the same scale, for several different values of kick strength. The radius of the atom cloud obeys the equation $r(t) = \sqrt{r_0^2 + v_{rms}^2 t^2}$,

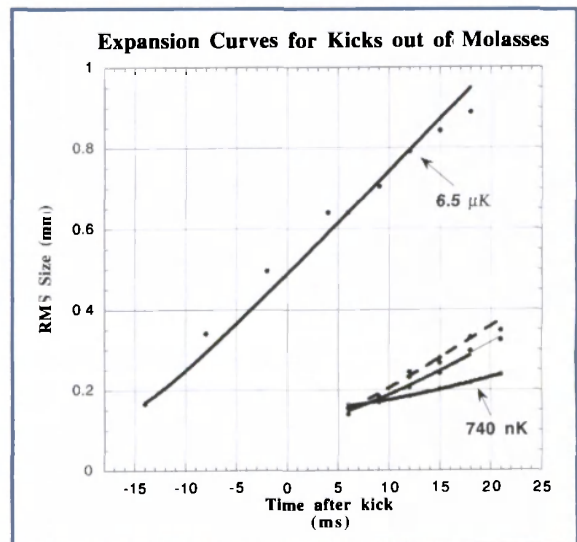

Fig. 10 Expansion curves for several values of kick strength, and one for free expansion (no kick). Smaller slopes in expansion curves indicate lower velocities and therefore temperatures.

where r_0 is the initial cloud radius and v_{rms} is the root mean square velocity of the atoms. The temperatures as obtained from a fit of this form are shown in the figure for the free expansion and for the delta kick which attained the lowest temperature of 740 nK. This temperature is limited only by the length of time for which we can currently allow the atoms to expand freely; with an additional potential supporting the atoms against gravity, there would be no fundamental limitation at all. One surprise is that extrapolating the 740 nK expansion curve back to the instant of the kick yields an initial size significantly smaller than the size of the atom cloud at that moment. We do not yet have a full understanding of this effect. It appears that the $m_F = 3$ atoms (which experience the bulk of the cooling) have a different spatial distribution than the rest of the atom cloud. We hope that further use of these delta-kicks for Stern-Gerlach-like probes of cold atom clouds will shed more light on the distribution of atoms produced by laser cooling.

Figure 11 shows the dependence of final temperature on the expansion of the atom cloud, and confirms our prediction that by waiting for the cloud size to increase significantly, one can achieve substantial cooling. As discussed earlier, the delta kick acts like a lens for atoms, and by using an overly strong current pulse, we may actually "focus" the atoms back towards the origin. Expansion curves are shown in Figure 12 for a variety of kick strengths. It should be noted that just as in gaussian beam optics, the more

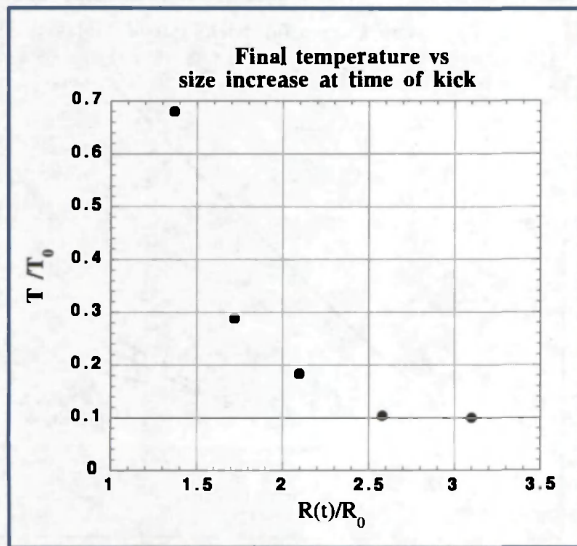

Fig. 11 The ratio of the final temperature, T , to the initial temperature, T_0 , versus the ratio of the radius of the atom cloud right before the kick, $R(t)$, to the initial cloud radius, R_0 .

tightly one attempts to focus the atoms, the higher their temperature (the equivalent of an optical beam's divergence angle) must be. A large, collimated atom cloud corresponds to the lowest attainable temperature.

ULTRACOLD ATOMS AND TUNNELING

Although by combining standard optical molasses with the new technique of "delta-kick cooling" we have produced the coldest atoms in Canada, at temperatures corresponding roughly to the momentum of a single photon, by no means have we reached the end of our journey. The thermal de Broglie wavelength of our atoms has been increased from Ångströms up to nearly a micron. This puts us within striking range of being able to *image* an atom cloud with resolution better than the atom's wavelength. If we can decrease the momentum by another factor of 10, yielding wavelengths near 8 microns, we will be able to take pictures of an atom's quantum wavefunction. More exciting yet, the wave nature of the atom should become evident at a

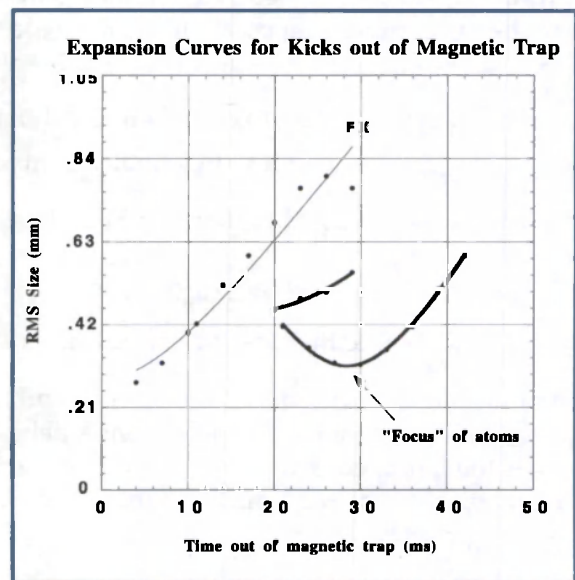

Fig. 12 Expansion curves for non-ideal kicks.

In one case, size decreasing immediately after the kick is the atomic analogue of a lens focusing light. The atoms reach a minimum radius, and then expand again at a higher rate than that of free expansion, signaling that they are actually hotter after this kick. The curve for which expansion does not stop, but merely keeps expanding at a slower rate, signifies a kick which was not strong enough. A free expansion is shown for comparison.

directly observable level.

Consider an atom impinging on a narrow, repulsive barrier. If the wavelength of the atom is comparable to the barrier thickness, we should begin to observe quantum tunneling. The entire atom, with its 37 protons, 48 or 50 neutrons, and 37 electrons, may appear on the far side of the barrier as a single unit. Now, an atom in an off-resonant light field develops an electric polarisation at the optical frequency. For light tuned above the resonance frequency, the response lags behind the driving field by 180° , and there is an energy cost associated with this out-of-phase polarisation. Thus the atom is repelled by an intense, blue-detuned light beam. We plan to focus a half-watt beam of 770 nm light to a narrow stripe, about 5 microns across. Such a barrier can easily repel ultracold atoms, but once the de Broglie wavelength reaches the micron scale, tunneling should begin to occur. Better yet, the 5-micron barrier width will allow us to directly image the barrier traversal. Not only will we be able to spatially distinguish incident from transmitted atoms--eventually, we plan to study the atoms while they are in the "forbidden region" itself^[16, 17].

How can we achieve such wavelengths, corresponding to temperatures in the 10 nK range? These temperatures are routinely achieved in Bose-condensation experiments, but at a high cost -- 99.9% of the atoms are typically lost in the evaporative cooling process. How can we avoid this sacrifice? We take advantage of the fact that we are looking for a one-dimensional effect. If we can reduce the momentum in one dimension by a factor of 10, leaving the atoms at *transverse* temperatures of several microKelvin, our one-dimensional tunneling experiment will become feasible. One way to do this is simply to *velocity-select* the slowest atoms from our 700 nK cloud. Our plan is to perform this selection by slowly sliding a barrier through a magnetically trapped atom cloud as shown in Figure 13.

Any atoms with energies higher than the barrier height will spill over the top, remaining trapped at the bottom of the magnetic well. Lower-energy atoms, on the other hand, will be adiabatically swept up the side of the potential, forming a cold, dense cloud held between a magnetic field gradient and the repulsive light field. A beam much broader than the de Broglie

wavelength will initially be used, to prevent tunneling, and once a cold sample is obtained, the beam waist will be reduced to allow tunneling to begin. This geometry has the useful side-effect that it introduces a sharp cutoff in energy. Instead of a smooth Boltzmann distribution, we will be able to select only those atoms with less energy than the barrier height, thus ensuring that all transmitted atoms have in fact tunneled through the barrier, rather than merely washing over it in a classically allowed fashion.

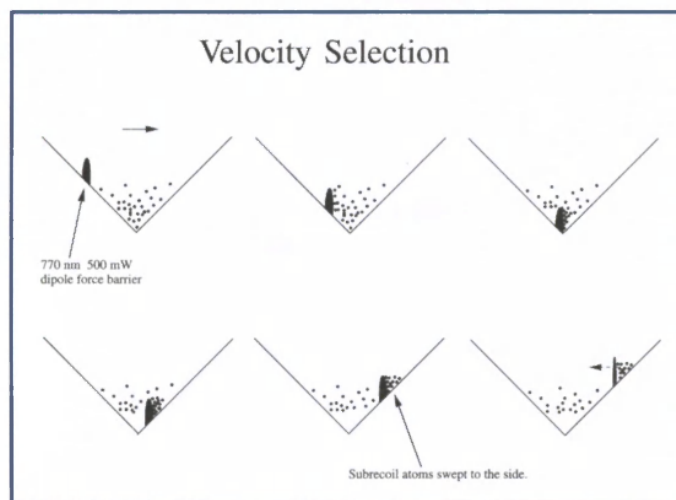

Fig. 13 This cartoon demonstrates our velocity-selection proposal: by sliding a repulsive barrier through our cloud of trapped atoms, we will transfer all the low-energy atoms to an auxiliary trap above the Gaussian barrier. Any atoms with higher energy than this barrier will spill over, remaining in the central trap. In the end, we will be left with only the coldest atoms in the secondary trap, and by adjusting the height and width of our barrier, will be able to study tunneling out of this quasi-bound state.

Quantum-mechanical simulations confirm the viability of this procedure, suggesting that we can retain up to about 5% of our atoms, and still reach temperatures below 10 nK, i.e., wavelengths above several microns. We even believe that we will be able to observe the quantum nature of this velocity-selection process, placing a large fraction of the atoms in the ground state of the auxiliary potential well formed by the laser beam and the magnetic field (see Figure 14). Observing the decay of this auxiliary trap due to tunneling will be a first step in our investigations of this still-mystifying process.

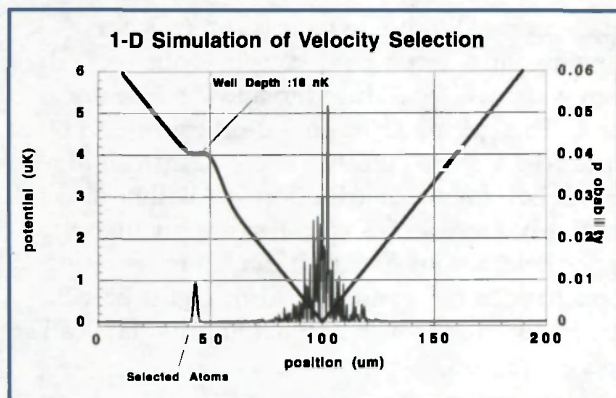

Fig. 14 These simulations show the wave function of an atom initially at $1.3 \mu\text{K}$, after a repulsive gaussian barrier has been slid through the attractive V-shaped trapping potential. Two components are clearly seen in the wave function: a "noisy", high-energy region at the bottom of the trap, and a single peak, corresponding to the single quasi-bound state supported by the 16 nK-deep well sandwiched between the gaussian and the side of the trap. Approximately 5% of the atoms are in this ultracold state.

CONCLUSIONS

Using simple techniques combining lasers and magnetic fields, it is now straightforward to cool atoms from room temperature down to the microKelvin range. Applying concepts from first-year physics, one can cool by another factor of ten into the nanoKelvin range, and in the future we hope to extend this result even further. One of the remarkable features of such cold atoms is their extremely long wavelength. Only very recently have long enough wavelengths been achieved that the quantum-mechanical behaviour of whole atoms can start to be observed through direct imaging. This promises to be a fantastically fruitful area for studying deep questions in quantum mechanics, aside from the many proposed applications of ultracold atoms in fields ranging from gravity-measurement to semiconductor lithography. Beyond a simple confirmation of atoms' ability to tunnel through optical barriers, we plan to study issues concerning whether a particle may be detected while tunneling; what happens to its energy when it is found to be in the classically forbidden region; how long it spends traversing that region; and so forth^[18,19]. We expect that the same system may be applied to studying "quantum chaos", at the boundary between classical and quantum behaviour, and other strange and

wonderful effects which occur when quantum objects are subjected to time-dependent potentials^[20]. Like many frontiers, the march to lower temperatures promises to provide not only new discoveries, but beautiful vistas along the way.

REFERENCES

1. Hansch, T. and Schawlow A., *Opt. Commun.*, **13**, 68 (1975).
2. D.J. Wineland and H. Dehmelt, *Bull. Am. Phys. Soc.* **20**, 637 (1975)
3. M.H. Anderson, J.R. Ensher, M.R. Matthews, C.E. Wieman, and E.A. Cornell, *Science* **269**, 198 (1995).
4. K.B. Davis, M.-O. Mewes, M.R. Andrews, N.J. van Druten, D.S. Durfee, D.M. Kurn, and W. Ketterle, *Phys. Rev. Lett.* **75**, 3639 (1995).
5. M.-O. Mewes, M.R. Andrews, D.M. Kurn, D.S. Durfee, C.G. Townsend, and W. Ketterle, *Phys. Rev. Lett.* **78**, 582 (1997)
6. E.W. Hagley, L. Deng, M. Kozuma, J. Wen, K. Helmerson, S.L. Rolston, and W.D. Phillips, *Science* **283**, 1706 (1999). I. Bloch, T.W. Hänsch, and T. Esslinger, *Phys. Rev. Lett.* **82**, 3008 (1999).
7. L. Deng, E.W. Hagley, J. Wen, M. Trippenback, Y. Band, P.S. Julienne, J.E. Simsarian, K. Helmerson, S.L. Rolston, and W.D. Phillips, *Nature* **398**, 218 (1999).
8. A.M. Steinberg, S. Myrskog, H.S. Moon, H.A. Kim, J. Fox, and J.B. Kim, *Annalen der Physik* **7**, 593 (1998).
9. M.-C. Gagné, J.S. Boulanger, and R.J. Douglas, *Can. J. Phys.* **76**, 577 (1998); and references therein.
10. L. Buchman, *Physics in Canada* **55**, 53 (1999).
11. J.A. Behr *et al.*, *Phys. Rev. Lett.* **79**, 375 (1997).
12. P.D. Lett, R.N. Watts, C.I. Westbrook, W.D. Phillips, P.L. Gould, and H.J. Metcalf, *Phys. Rev. Lett.* **61**, 169 (1988).
13. J. Dalibard, and C. Cohen-Tannoudji, *J. Opt. Soc. Am. B* **6**, 2023 (1989)
14. H. Ammann and N. Christensen, *Phys. Rev. Lett.* **78**, 2088 (1997)
15. É. Maréchal, S. Guibal, J.-L. Bossennec, M.-P. Gorza, R. Barbé, J.-C. Keller and O. Gorceix, *Eur. Phys. J.* **2**, 195 (1998).
16. S.H. Myrskog, J.K. Fox, H.S. Moon, H.A. Kim, J.B. Kim, and A.M. Steinberg, to be published (LANL preprint quant-ph/9812031).
17. A.M. Steinberg, "On energy transfer by detection of a tunneling atom", to appear in *J. Kor. Phys. Soc.*, (1999).
18. A.M. Steinberg, *Superlatt. and Microstruct.* **23**, 823 (1998).
19. A.M. Steinberg, "Can a falling tree make a noise in two forests at the same time?", in *Causality and Locality in Modern Physics and Astronomy*, G. Hunter, S. Jeffers, and J.-P. Vigiér eds. (Kluwer Academic Press, 1998), p. 431.
20. J.C. Robinson *et al.*, *Phys. Rev. Lett.* **76**, 3304 (1996).