

PHY131H1F - Hour 24

Today:

8.3 Static Equilibrium

8.4 Centre of Mass

+ Ch.5-7 Review

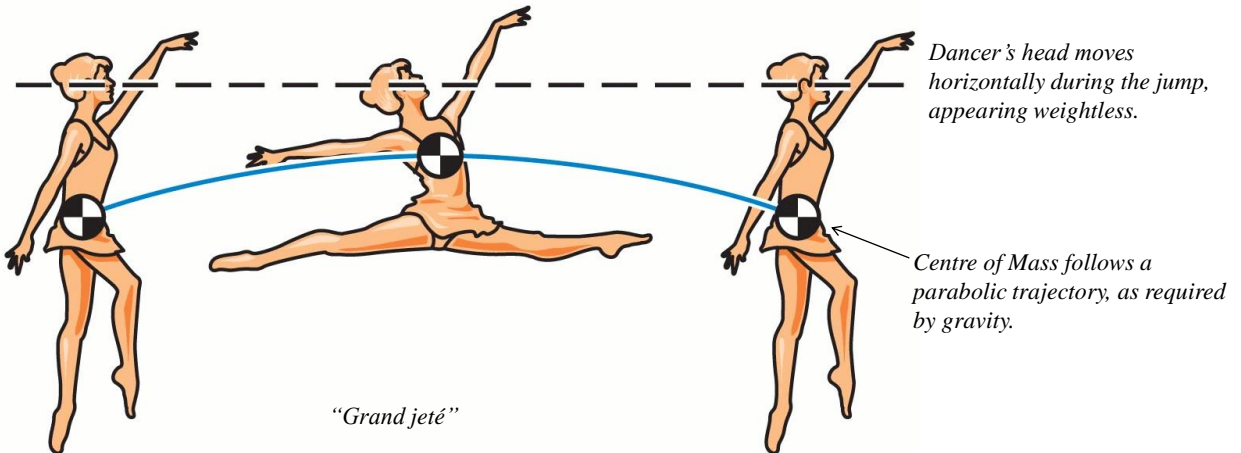

<http://www.chegg.com/homework-help/questions-and-answers/grand-jete-classic-ballet-manoevre-dancer-executes-horizontal-leap-moving-arms-legs-cent-q5975347>

Learning Catalytics Question

- What does it imply if the torque of a 10 N force is zero?
 - A. The force is exerted at the axis of rotation.
 - B. A line parallel to the force and passing through the place where the force is exerted passes through the axis of rotation.**
 - C. It is not possible for a 10 N force to produce zero torque.

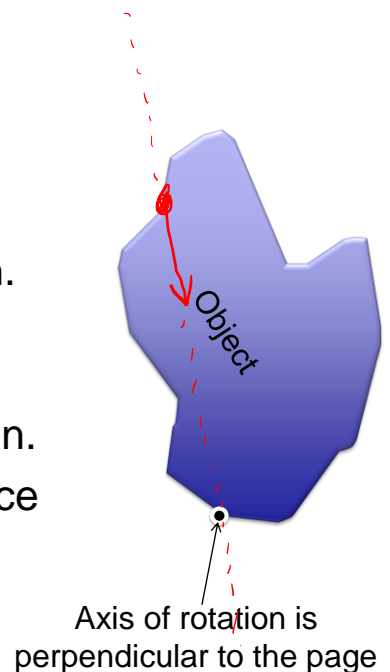

8.3 Skills for analyzing situations using equilibrium conditions

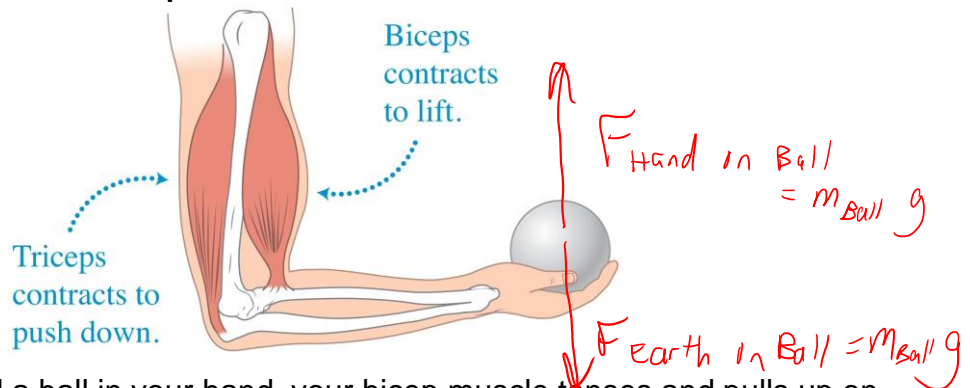

- When you hold a ball in your hand, your bicep muscle tenses and pulls up on your forearm in front of the elbow joint.
- When you push down with your hand on a desk, your triceps muscle tenses and pulls up on a protrusion of the forearm behind the elbow joint.
- The equations of equilibrium allow you to estimate these muscle tension forces

8.3 Skills for analyzing situations using equilibrium conditions

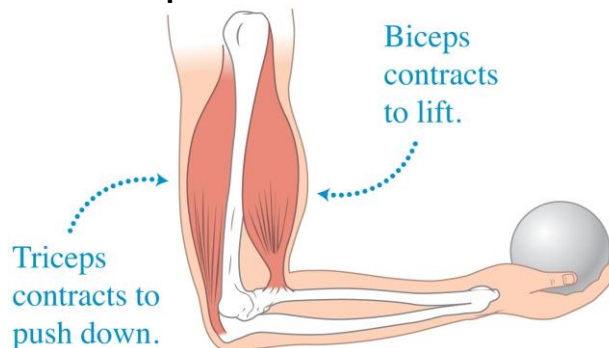

- **Example Problem:**
- You hold a 6.0 kg lead ball in your hand with your arm bent, as shown. The ball is 35 cm from the elbow joint. The biceps attach to the forearm 5.0 cm from the elbow joint. The forearm has a mass of 1.2 kg, and its centre of mass is 16 cm from the elbow joint. What is (a) the force of the biceps on the forearm, and (b) the force of the upper arm on the elbow joint?

Example 8.5. You hold a 6.0 kg lead ball in your hand with your arm bent, as shown. The ball is 35 cm from the elbow joint. The biceps attach to the forearm 5.0 cm from the elbow joint. The forearm has a mass of 1.2 kg, and its centre of mass is 16 cm from the elbow joint.

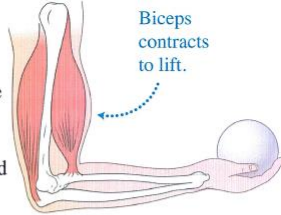

What is (a) the force of the biceps on the forearm, and (b) the force of the upper arm on the elbow joint?

Sketch and translate

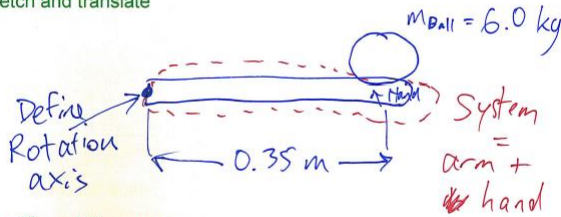

Simplify and diagram

System = rigid body
Let's draw an extended force diagram.

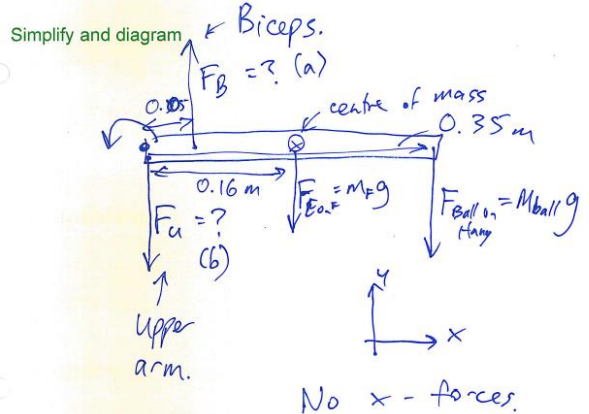

Represent mathematically

$$\begin{cases} \sum F_y = 0 \\ \sum \tau = 0 \end{cases}$$

2 eqs. 2 unknowns, solve for F_B , F_U

What is (a) the force of the biceps on the forearm, and (b) the force of the upper arm on the elbow joint?

Solve and Evaluate

$$\begin{aligned} \sum F_y &= F_B - F_U - m_F g - m_{Ball} g = 0 \\ F_B - F_U &= g(m_F + m_{Ball}) \\ &= 9.8(1.2 + 6) = 70.6 \text{ N} \end{aligned}$$

$$\begin{aligned} \sum \tau &= 0 + 0.05 F_B - 0.16 m_F g - 0.35 m_{Ball} g \\ &= 0 \end{aligned}$$

$$\begin{aligned} 0.05 F_B &= 0.16 m_F g + 0.35 m_{Ball} g \\ F_B &= \frac{[0.16] 1.2 (9.8) + [0.35] (6) (9.8)}{0.05} \end{aligned}$$

(a) $F_B = 449 \text{ N}$ (b) $F_B - F_U = 70.6$
 $\Rightarrow F_U = 449 - 70.6$

Very large \rightarrow larger than $m_{Ball} g = 60 \text{ N}$
 since Bicep acts closer to rotation axis.
 $F_U = 379 \text{ N}$

- **Centre of mass** is the average position of all the mass that makes up the object.
- **Centre of gravity (CG)** is the average position of weight distribution.
 - Since here on Earth weight and mass are proportional, centre of gravity and centre of mass always refer to the same point of an object.

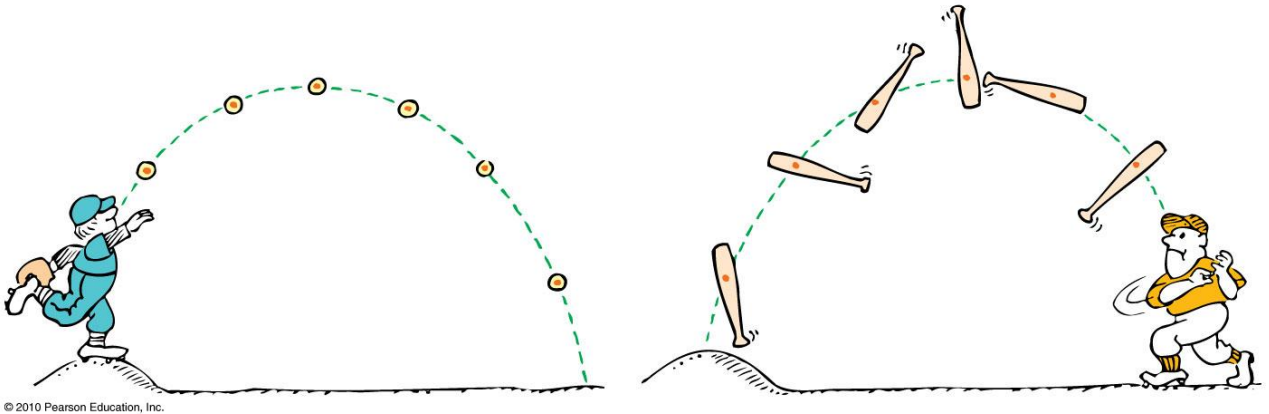

- How is it possible to clear the bar in a high jump if your center of mass does not reach to the height of the bar?
- ANSWER:

- For a projectile, the motion of the centre of mass is governed by the equations of constant acceleration we already know.

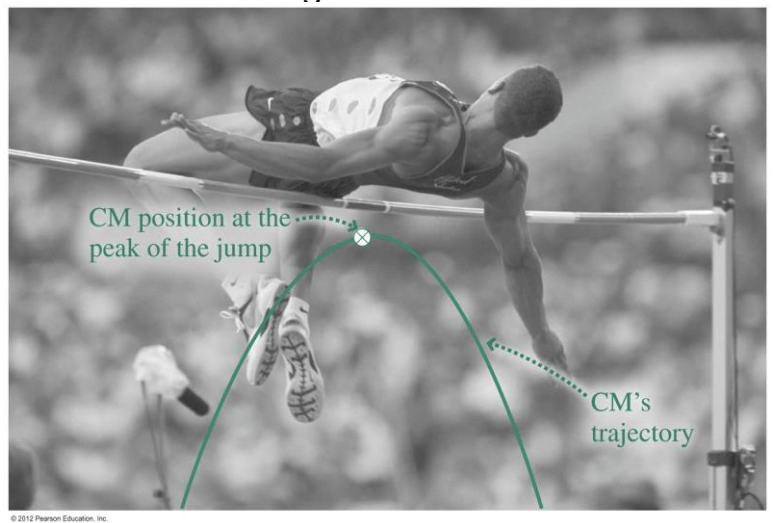

- The center of mass of a complicated shape (like a person doing a back arch) does not need to be within the object.

Learning Catalytics Question

- Where is the centre of mass of this doughnut?

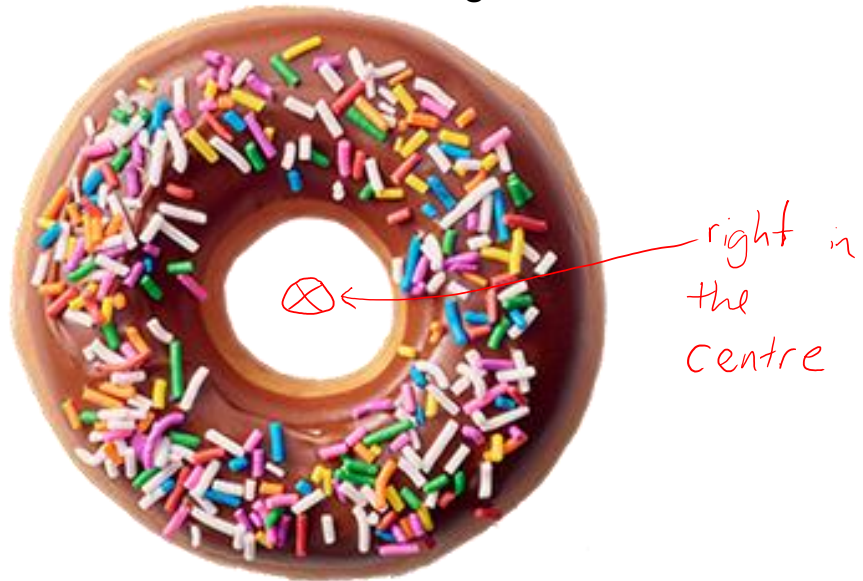

Center of Mass

Consider an object made of particles. Particle i has mass m_i . The center-of-mass is at

$$x_{\text{cm}} = \frac{1}{M} \sum_i m_i x_i = \frac{m_1 x_1 + m_2 x_2 + m_3 x_3 + \dots}{m_1 + m_2 + m_3 + \dots}$$

$$y_{\text{cm}} = \frac{1}{M} \sum_i m_i y_i = \frac{m_1 y_1 + m_2 y_2 + m_3 y_3 + \dots}{m_1 + m_2 + m_3 + \dots}$$

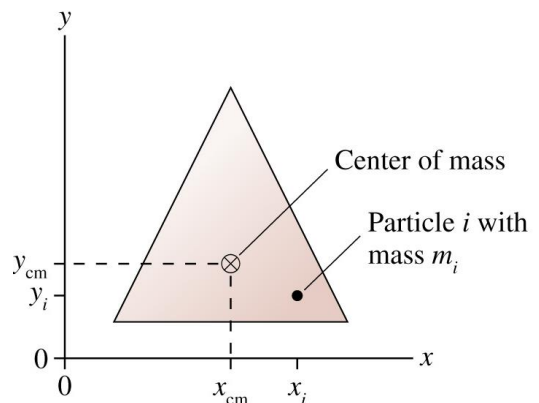

Calculating center of mass is much like calculating your grade-point average. Marks in full-courses count twice as much as marks in half-courses. Particles of *higher mass* count *more* than particles of lower mass.

Learning Catalytics Question

Water starts dripping at a constant rate into an empty plastic can through a small opening at the top, as shown.

Which graph shows the correct qualitative dependence of the vertical position of the center of mass of the water-can system (y_{cm}) on the height of the water level in the can (y_{water})?

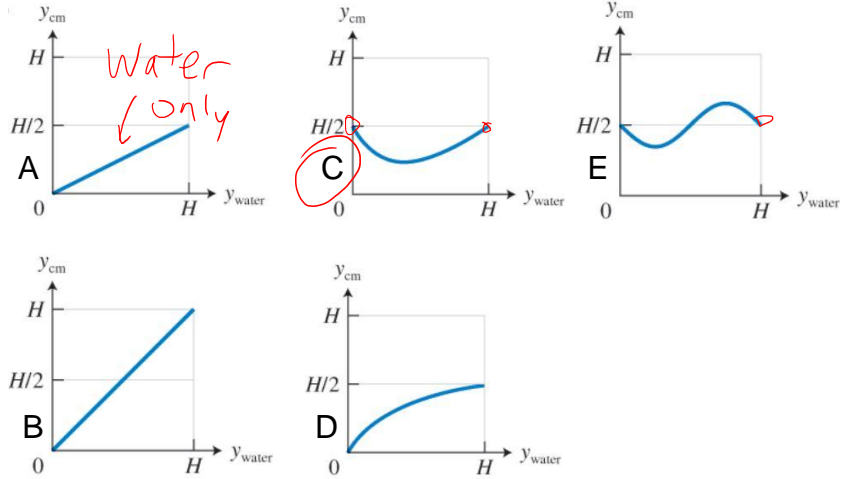
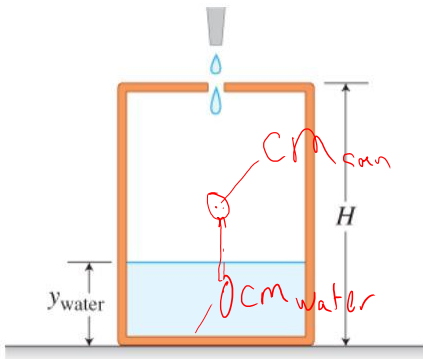

Demo and example

One block of length L is hanging off the edge of a table. How far off the edge can it go without tipping?

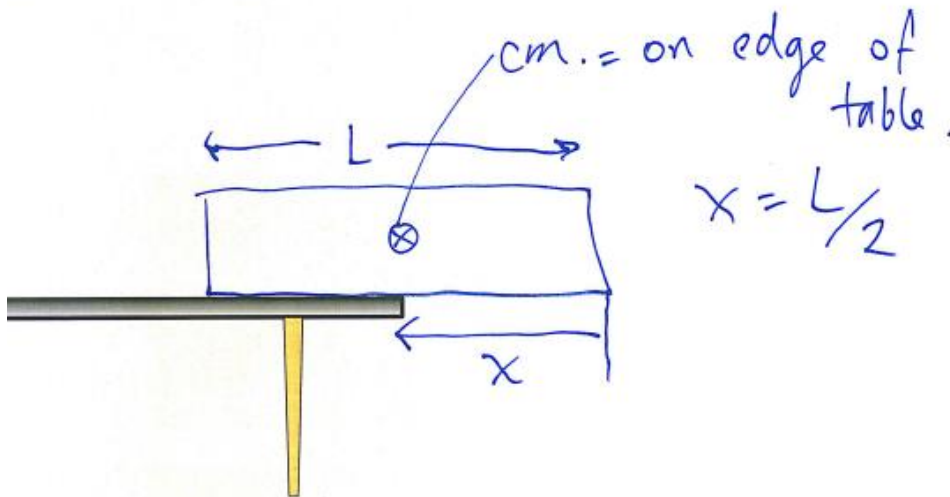

Two blocks have length L . The top one is hanging a distance $L/2$ off the one below it.

How far off the edge can the bottom block be before the entire stack topples over?

System = both blocks

define origin $x=0$

$$X = \frac{X_{\text{top}} m + X_{\text{bot}} m}{m + m}$$

$$= \frac{0m + \frac{L}{2}m}{2m}$$

$X = \frac{L}{4}$

Three blocks have length L . The top one is hanging a distance $L/2$ off the one below it. The one below that is hanging a distance $L/4$ off the one below it.

How far off the edge can the bottom block be before the entire stack topples over?

mass $2m$, $X_{\text{cm}} = 0$

origin $x = \frac{\frac{L}{2}m}{3m}$

$$X = \frac{0(2m) + \frac{L}{2}m}{2m + m}$$

$$X = \frac{L}{6}$$

4 blocks: $x = \frac{L}{8}$

5 blocks: $x = \frac{L}{10} \dots \text{etc.}$

Term Test 2 Info

- The second term test is tomorrow, Tue., Nov. 13, 6:10pm -7:30pm (80 minutes). The room is based on the first letter of your family name:
 - A - LOCH = EX200
 - LOKE - ZU = EX100
- Alternate sitting students have received a separate email letting you know the room and time.
- Testable material is:
 - Chapters 5, 6 and 7 of Etkina, plus material from Chs. 1-4, due to the cumulative nature of physics.
 - Hours 13 – 22 of class, from Oct.10-31, inclusive.
 - Practicals 4 - 7 and Homeworks 4 - 7, from Oct.9-Nov.12, inclusive.

Term Test 2 Info

- The format will be the same as for test 1 (except there's no sleep survey question). There will be 12 multiple choice questions, worth 2 points each, for which you answer on the scratch-card. Also there will be one written question, worth 8 points, for which you have to do the four-step problem solving method.
- **Aids allowed:** A pocket calculator with no communication ability (programmable calculators and graphing calculators are okay). A single hand-written aid-sheet prepared by the student, no larger than 8.5"x11", written on both sides. A hard-copy English translation dictionary. A ruler. A coin or similar object for the scratch-off card.
- Please be sure to bring your T-Card, as invigilators will be collecting signatures and checking your photo-ID.

Midterm Test 2 - hints



- **Don't be late.** If you're very early, just wait outside the room; we'll try to start letting people get seated at 5:55, but no one can start writing until 6:10.
- Once the test begins, spend the first 2 or 3 minutes skimming over the entire test from front to back before you begin. Look for the easy problems that you have confidence to solve first.
- Before you answer anything, read the question *very carefully*. The **most common mistake** is misreading the question!
- Manage your time; if you own a watch, bring it. 13 problems over 80 minutes means an average of about 6 minutes per problem.
- You **CANNOT HAVE YOUR PHONE** with you or in your pocket at a test or exam at U of T – you must store it in your backpack at the edge of the room, or in a special bag underneath your desk



Midterm Test 1 – *more hints!*

- Some of the multiple choice are conceptual and can be answered in less than 2 minutes.. Maybe do these ones first?
 - If you start a longer problem but can't finish it within about 10 minutes, leave it, make a mark on the edge of the paper beside it, and come back to it after you have solved all the easier problems.
 - When you are in a hurry and your hand is not steady, you can make little mistakes; if there is time, do the calculation twice and obtain agreement.
 - Bring a snack or drink.
- 
- Don't leave a test early! You might spend the first half getting 95% of the marks you're going to get, and the second half getting the other 5%, but it's still worth it.

Learning Catalytics survey:
How are you feeling about the test tomorrow?

-  A. I feel confident about the test tomorrow; I believe I will get an A
- B. I'm not too sure what to expect, but I'm hopeful I'll do well
-  C. I have no particularly positive or negative feelings about the test tomorrow..
- D. I'm not too sure what to expect, but I'm worried it will be awful
-  E. I am very worried about the test tomorrow; I'm afraid I'm going to fail!

Round 1

 225 responses

A. 12%

B. 36%

C. 13%

D. 20%

E. 18%

Chs.5-7 Review

Learning Catalytics Question

- A string is attached to the rear-view mirror of a car. A ball is hanging on the other end of the string. The car is driving around in a circle, at a constant speed. What direction is the ball accelerating?

- A. Up
- B. Horizontal to the left
- C. Horizontal to the right
- D. Diagonally up & to the left
- E. Diagonally up & to the right
- F. The ball is not accelerating

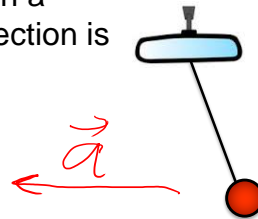

Chs.5-7 Review

Learning Catalytics Question

- A string is attached to the rear-view mirror of a car. A ball is hanging on the other end of the string. The car is driving around in a circle, at a constant speed. Which of the following lists gives all of the forces directly acting on the ball?

- A. Tension
- B. Tension, gravity, the centripetal force and friction
- C. Tension and gravity
- D. Tension, gravity and the centripetal force

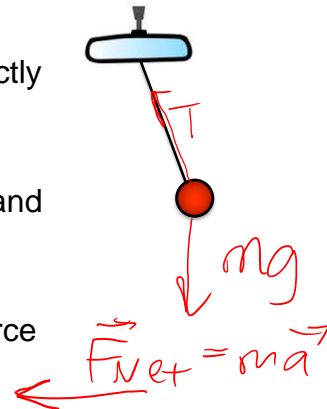

Chs.5-7 Review

- Centripetal Force **is** the Net force on an object moving in uniform circular motion!
- This net force is the vector sum of all the actual forces on the free body diagram.
- You do NOT draw centripetal force as an extra force acting on the object.

