

P.N.5520-5305-XX

PART NO.	a x b mm	A	B	C
5520-5305-02	2 X 2	5.6	8.5	5.8
5520-5305-03	3 X 3	6.3	9.9	7.2
5520-5305-04	4 X 4	7	11.3	8.6
5520-5305-05	5 X 5	7.7	12.8	10.1
5520-5305-06	6 X 6	8.4	14.1	11.5
5520-5305-07	7 X 7	9.1	15.6	12.9
5520-5305-08	8 X 8	9.8	17.0	14.3
5520-5305-09	9 X 9	10.5	18.4	15.7

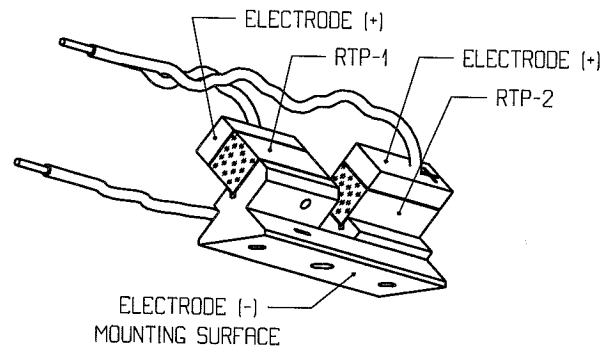
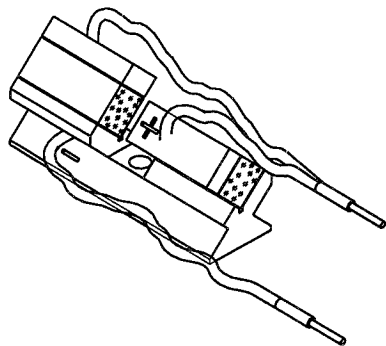

RTP O-SWITCH

TWO CRYSTALS 5 MM LENGTH

MECHANICAL INTERFACE

5520-5305-00

RAICOL CRYSTALS

LASERS, PROPOSAL 2, FIBRE 53101F1000  
55205310A4, 55205310B6, 55205310B9

VIEWS FOR INFORMATION ONLY