

NOTES

- MATERIAL - 20 GAUGE STEEL
- FOUR 6-32 NICKEL PLATED SCREWS
- 0.064" THICK ALUMINUM PANELS
- SELF ADHESIVE RUBBER FEET

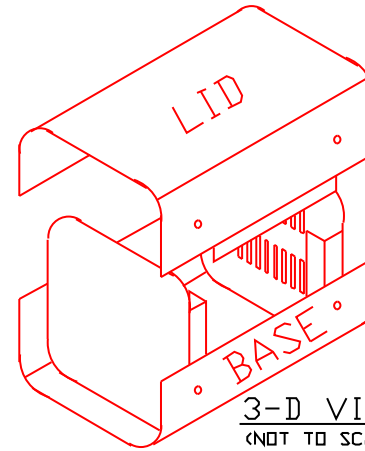

3-D VIEW
(NOT TO SCALE)

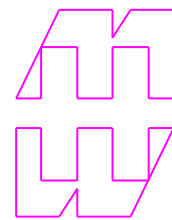
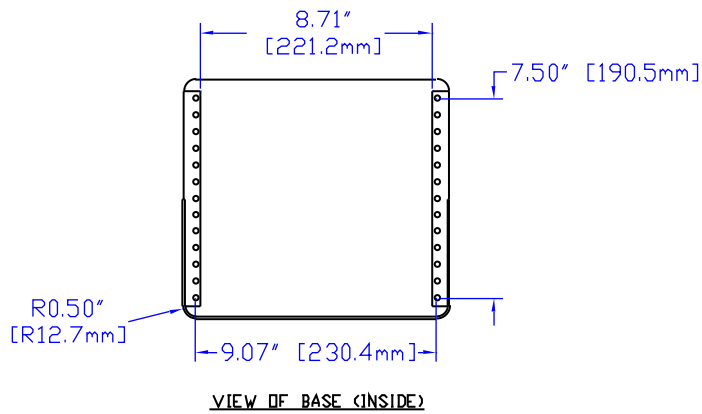
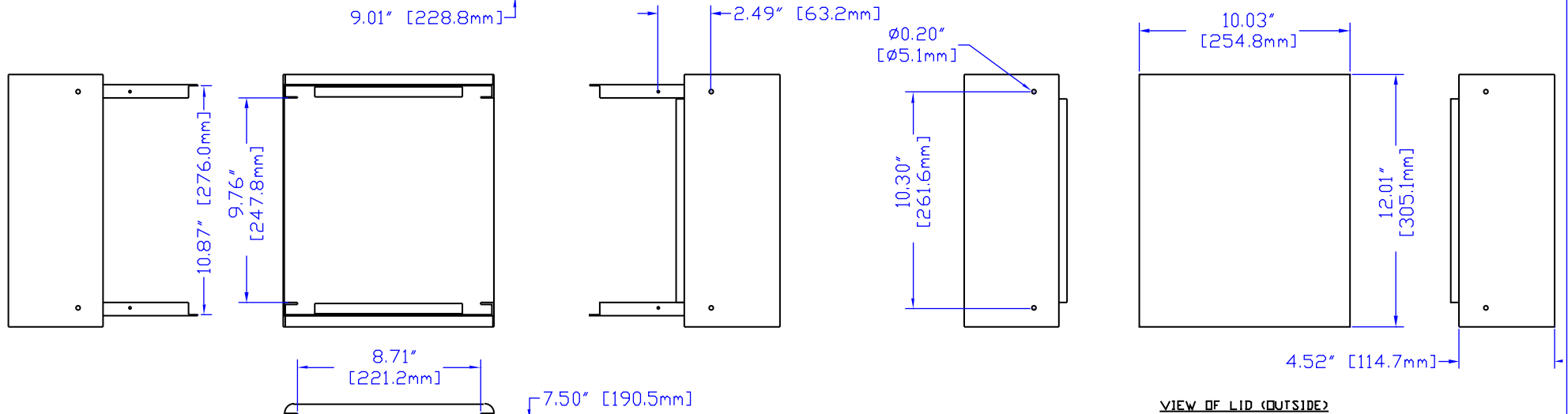
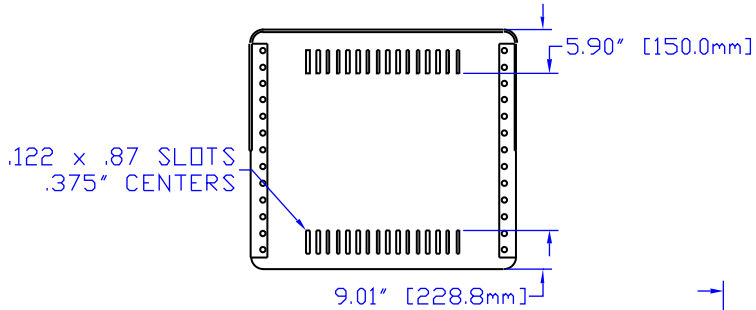

HAMMOND MANUFACTURING

1401G-Instrument

CANADA - PH (519) 886 7170 - FAX (519) 886 8311
U.S.A. - PH (716) 631 5700 - FAX (716) 631 1156