

QM-140V

QM-140V is an easy to mount LCD digital panel meter. The user need only drill a single 5.5mm / $\frac{7}{32}$ " hole in the panel. The module is fitted to the panel by locating its screw threaded stud through the hole, fitting the washer and tightening the nut provided. The module's 10 connecting wires pass through the hollow stud into the target application, where they can be easily soldered into place. The module features 200mV full scale input, auto-zero and auto-polarity. A separate screw terminal adaptor board (T/BLK-4) simplifies connection and calibration.

- Single Hole Mounting
- 200mV Full Scale Reading
- 12.5mm / 0.5" LCD Digit Height
- Auto-zero, Auto-polarity
- 10 Wire Connections
- Low Battery Warning
- Screw Terminal Board Option (T/BLK-4)



Easy Mounting Voltmeter Optional Screw Terminal Adaptor Board				Stock Number QM-140V T/BLK-4
Specification	Min.	Typ.	Max.	Unit
Accuracy (overall error)*		0.05	0.1	% (± 1 count)
Linearity			± 1	count
Displayed reading	-1999		1999	
Resolution		0.1		mV d.c.
Sample rate		3		sample/sec
Operating temperature range	0		50	$^{\circ}\text{C}$
Temperature stability		100		ppm/ $^{\circ}\text{C}$
Supply voltage	7.5	9	15	V d.c.
Supply current		150		μA

* To ensure maximum accuracy, re-calibrate periodically.

SAFETY

To comply with the Low Voltage Directive (LVD 93/68/EEC), input voltages to the module's pins must not exceed 60Vd.c. If voltages to the measuring inputs do exceed 60Vd.c., then fit scaling resistors externally to the module. The user must ensure that the incorporation of the meter into the user's equipment conforms to the relevant sections of BS EN 61010 (Safety Requirements for Electrical Equipment for Measuring, Control and Laboratory Use).

DIMENSIONS All dimensions in mm (inches)

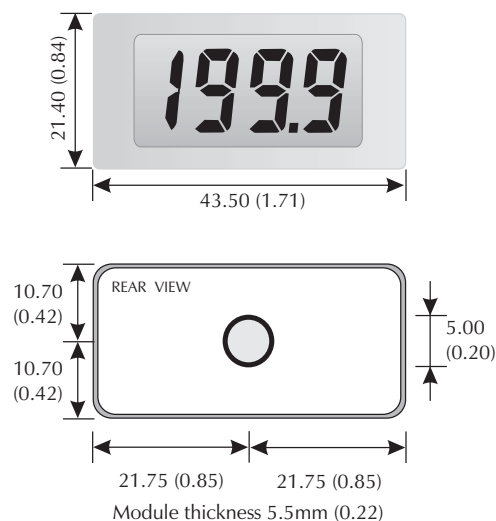

FITTING THE QM-140V

Drill a 5.5mm / $\frac{7}{32}$ " hole in the panel. Fit the module to the panel by passing its screw threaded stud through the hole, fitting the washer and tightening the nut provided. Take care not to trap any of the connecting wires. Do not to overtighten the nut as this may damage the meter.

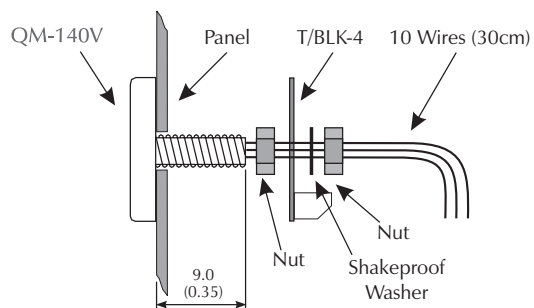

If T/BLK-4 is not fitted, then do not fit the first nut.

WIRE CONNECTIONS (QM-140V) and SCREW TERMINAL FUNCTIONS (T.BLK-4)

- | | | |
|----------------|--------|---------------------------------------------------------------------------------------------------------------------------------------------------------------------------------------------------------------|
| 0. Black (BK) | V- | Negative power supply connection. |
| 1. Brown (BR) | COM | The ground for the analogue section of the A/D converter, held actively at 2.8V (nom.) below V+.
COM must not be allowed to sink excessive current (>100µA) by connecting it directly to a higher voltage. |
| 2. Red (RD) | V+ | Positive power supply connection. |
| 3. Orange (OR) | Vref | Connection for calibration circuit (see diagram below). |
| 4. Yellow (YL) | IN HI | Positive measuring differential input. |
| 5. Green (GN) | IN LO | Negative measuring differential input. |
| 6. Blue (BL) | DP COM | Common connection for decimal points DP1, DP2 and DP3, see below. |
| 7. Violet (VI) | DP1 | 199.9 |
| 8. Grey (GY) | DP2 | 19.99 |
| 9. White (WT) | DP3 | 1.999 |
- Connect to DP COM to display required decimal point.
(or make appropriate solder link on T/BLK-4)

SCALING and CALIBRATION

A calibration circuit and two resistors (Ra and Rb) may be added on the QM-140V or T/BLK-4 board (cut Link La if fitting Ra) to alter the full scale reading of the meter - see table. Note that the meter will have to be (re-)calibrated by adjusting the potentiometer.

Required F.S.R.	Ra	Rb	CAL
200mV	N/A	N/A	Adjust
2V	910k	100k	Adjust
20V	1M	10k	Adjust
200µA	0R	1k	Adjust
2mA	0R	100R	Adjust
20mA	0R	10R	Adjust
200mA	0R	1R	Adjust

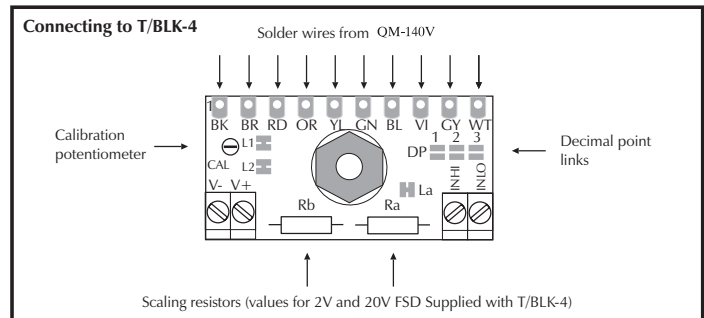

Adding an input filter and scaling resistors when T/BLK-4 is not used

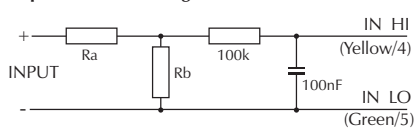

Note: To reduce noise on the meter's input, fit the input filter components (1M and 10nF) shown above. The input filter is fitted as standard on T/BLK-4.

Adding a calibration circuit when T/BLK-4 is not used

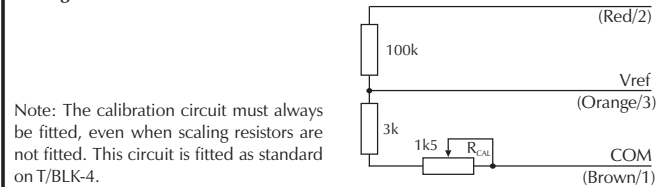

APPLICATIONS

Do not connect more than one meter to the same power supply if the meters cannot use the same signal ground. Taking any input beyond the power supply rails will damage the meter. Keep leads short to ensure noise-free operation.

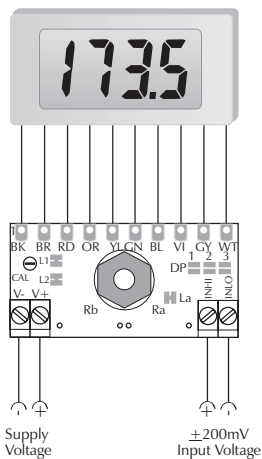

Measuring a floating voltage source of 200mV full scale.
Add Ra and Rb and cut Link La to increase the measurement range.

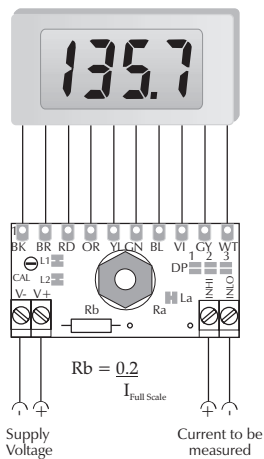

Measuring current.
Recalibrate the module.
The current to be measured must be isolated from the module's power supply.

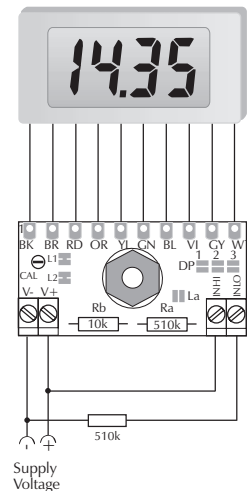

Measuring a supply voltage.
(min. 7.5V, max. 15V)
Cut Links La and L2.
Recalibrate the module.