

Rotary switch is crap. Replace with real one such as 71BDF36-01-1-AJN.

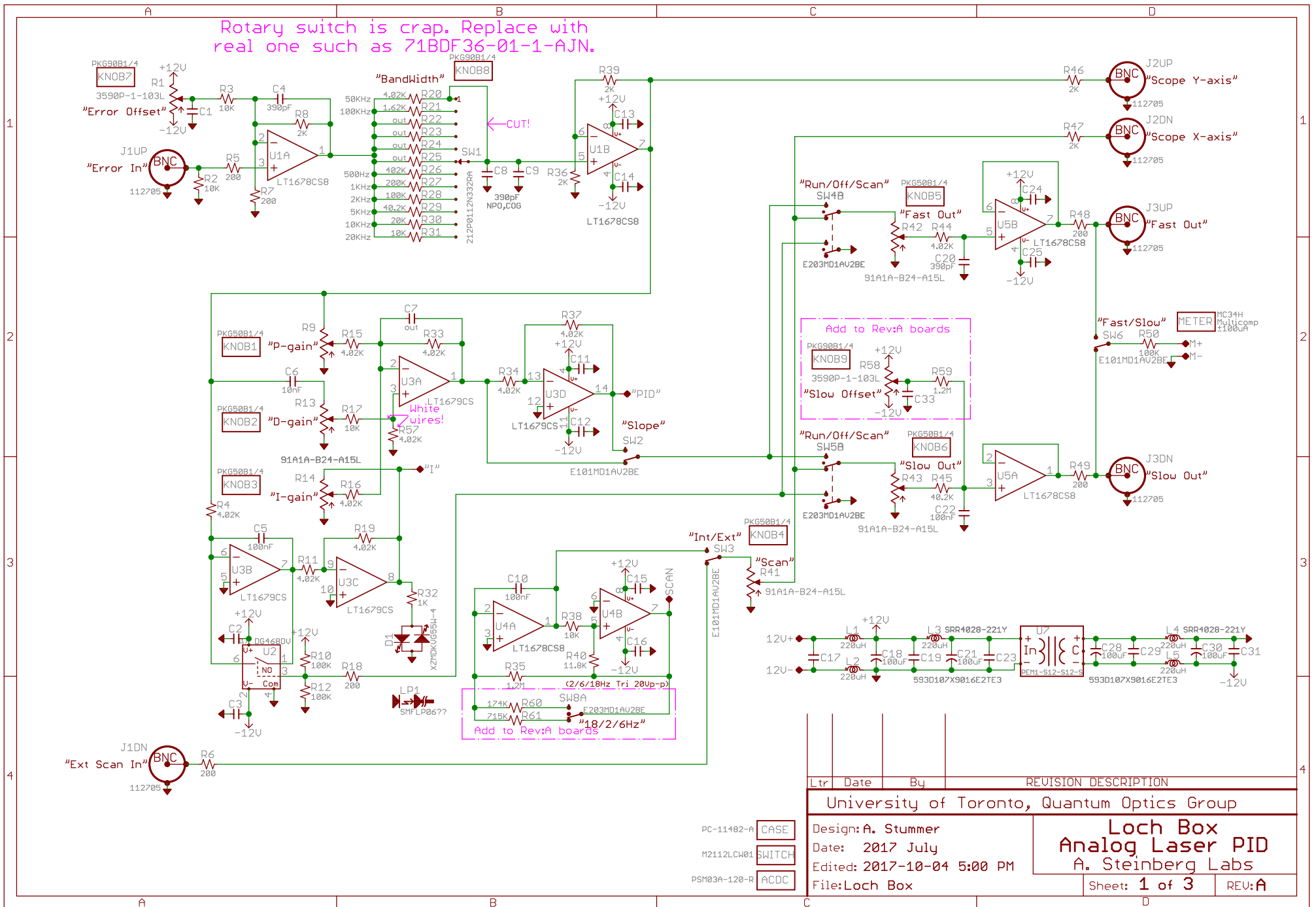

Ltr	Date	By	REVISION DESCRIPTION
University of Toronto, Quantum Optics Group			
PC-11482-A		CASE	Design: A. Stummer
M2112LCW01		SWITCH	Date: 2017 July
PSM03A-120-R		ACDC	Edited: 2017-10-04 5:00 PM
File:Loch Box			Sheet: 1 of 3
			REV:A

**Loch Box**  
**Analog Laser PID**  
 A. Steinberg Labs

This page is an add-on because there is so much space left on the board and I need this amplifier for the Teledyne-LeCroy WS3054 scope's Wave Source. The latter is only  $\pm 3V$  (no load) but sometimes I need up to  $\pm 10V$ .

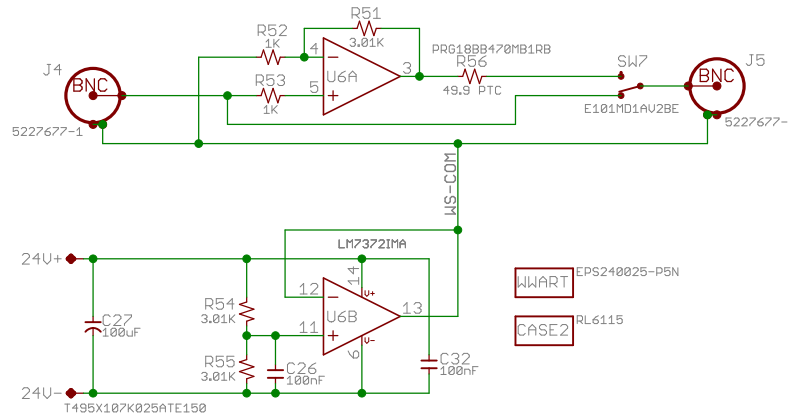

University of Toronto  
Quantum Optics Group

Loch Box  
A. Steinberg Labs

Back Panel, inside view, 0.060" A1

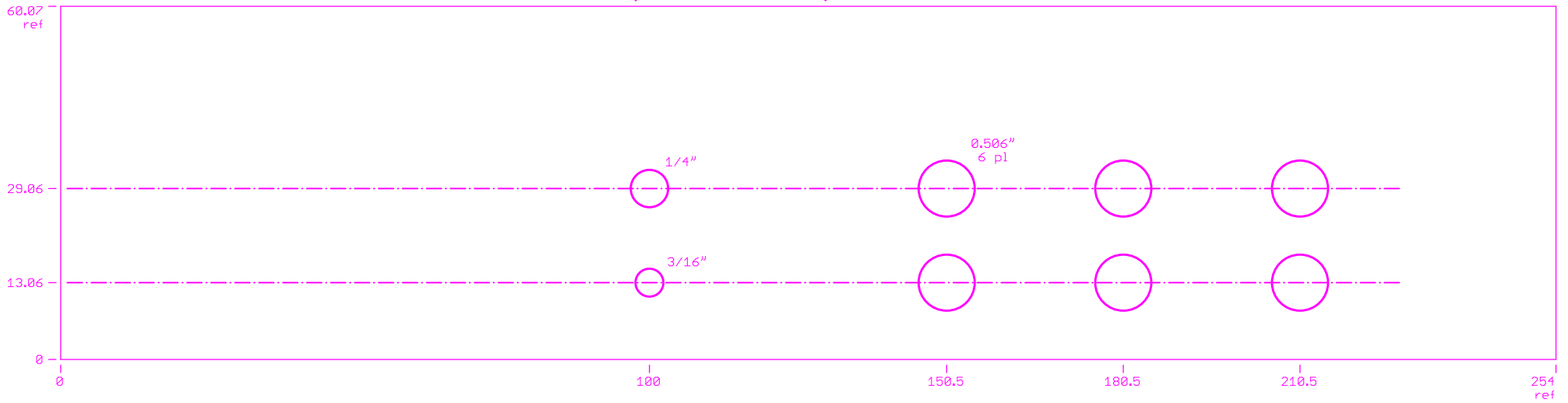

Front Panel, front view, 0.060" A1

