

PHY131H1F - Class 18

Today:

- **Today, Chapter 11:**
- Angular velocity and Angular acceleration vectors
- Torque and the Vector Cross Product
- Angular Momentum
- Conservation of Angular Momentum
- Gyroscopes and Precession



Learning Catalytics

Question (part 1 of 2)

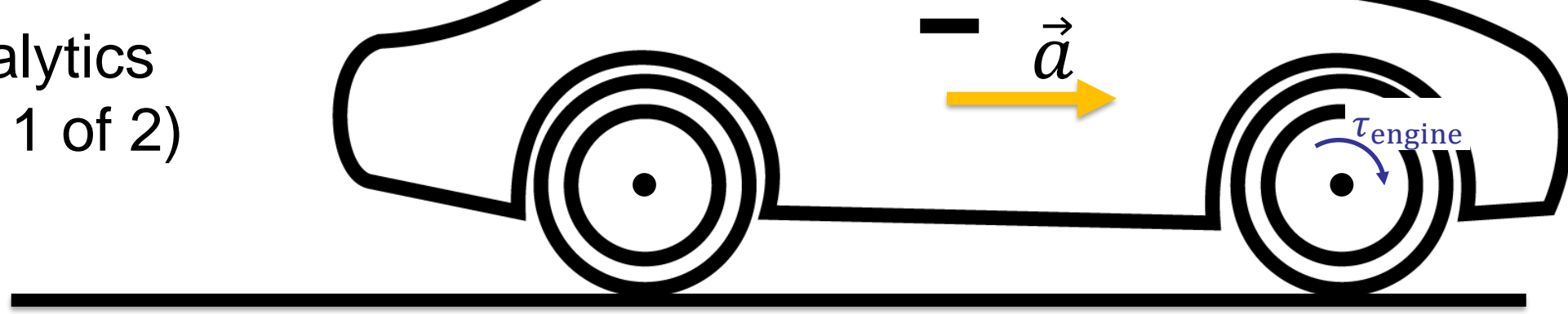

You are sitting in your car, and you step on the gas pedal. The car accelerates forward.

Your car has Front Wheel Drive (FWD). That means the front two wheels are connected to the engine, but the back two wheels just freely rotate on their axles.

As you accelerate, what is the direction of the force of static friction of the road upon the **front** wheels?

- A. Forward
- B. Backward
- C. The static friction force on the front wheels is zero

Learning Catalytics

Question (part 2 of 2)

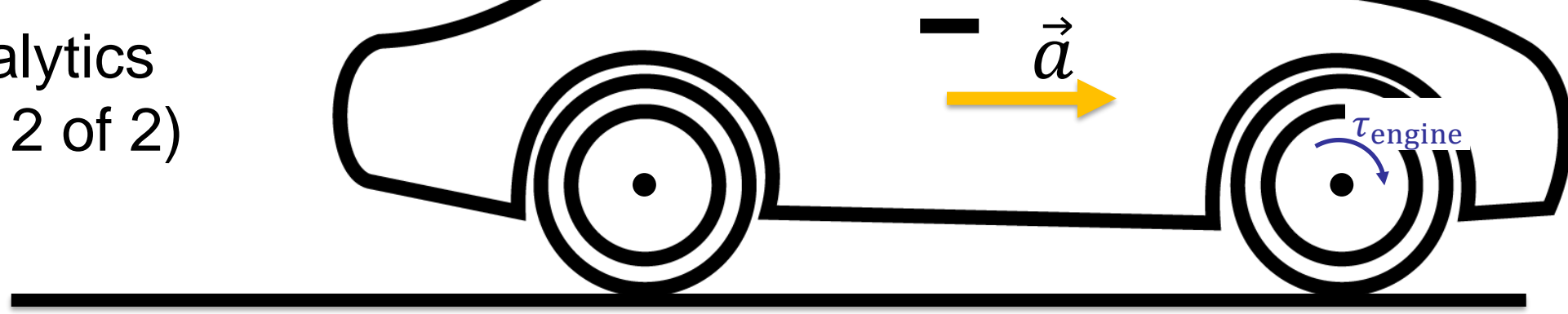

You are sitting in your car, and you step on the gas pedal. The car accelerates forward.

Your car has Front Wheel Drive (FWD). That means the front two wheels are connected to the engine, but the back two wheels just freely rotate on their axles.

As you accelerate, what is the direction of the force of static friction of the road upon the **rear** wheels?

- A. Forward
- B. Backward
- C. The static friction force on the rear wheels is zero

The Vector Description of Rotational Motion

- One-dimensional motion uses a scalar velocity v and force F .
- A more general understanding of motion requires vectors \vec{v} and \vec{F} .
- Similarly, a more general description of rotational motion requires us to replace the scalars ω and τ with the vector quantities $\vec{\omega}$ and $\vec{\tau}$.
- Doing so will lead us to the concept of *angular momentum*.

The Angular Velocity Vector

- The magnitude of the angular velocity $\vec{\omega}$ vector is ω .
- The angular velocity vector points along the axis of rotation in the direction given by the right-hand rule as illustrated.

1. Using your right hand, curl your fingers in the direction of rotation with your thumb along the rotation axis.
2. Your thumb is then pointing in the direction of $\vec{\omega}$.

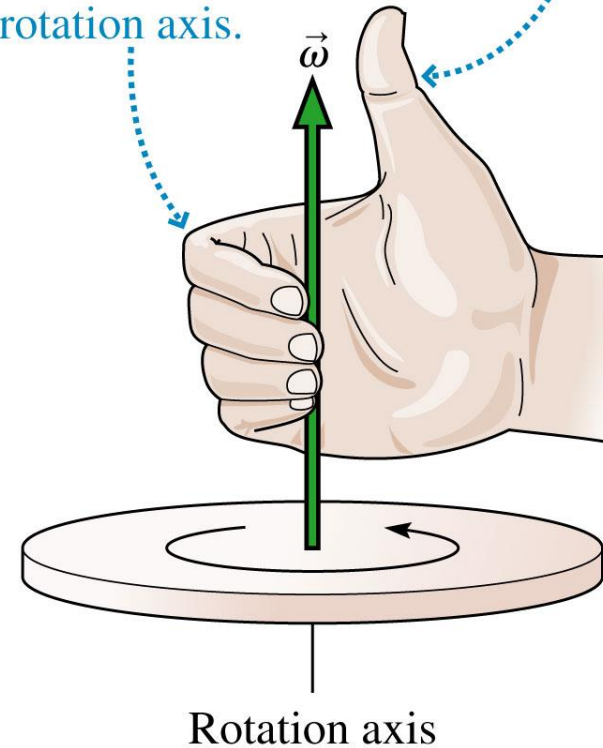

The Cross Product of Two Vectors

The *scalar product (dot)* is one way to multiply two vectors, giving a scalar. A different way to multiply two vectors, giving a vector, is called the **cross product**.

If vectors \vec{A} and \vec{B} have angle α between them, their cross product is the vector:

$$\vec{A} \times \vec{B} \equiv (AB \sin \alpha, \text{ in the direction given by the right-hand rule})$$

The cross product is perpendicular to the plane.

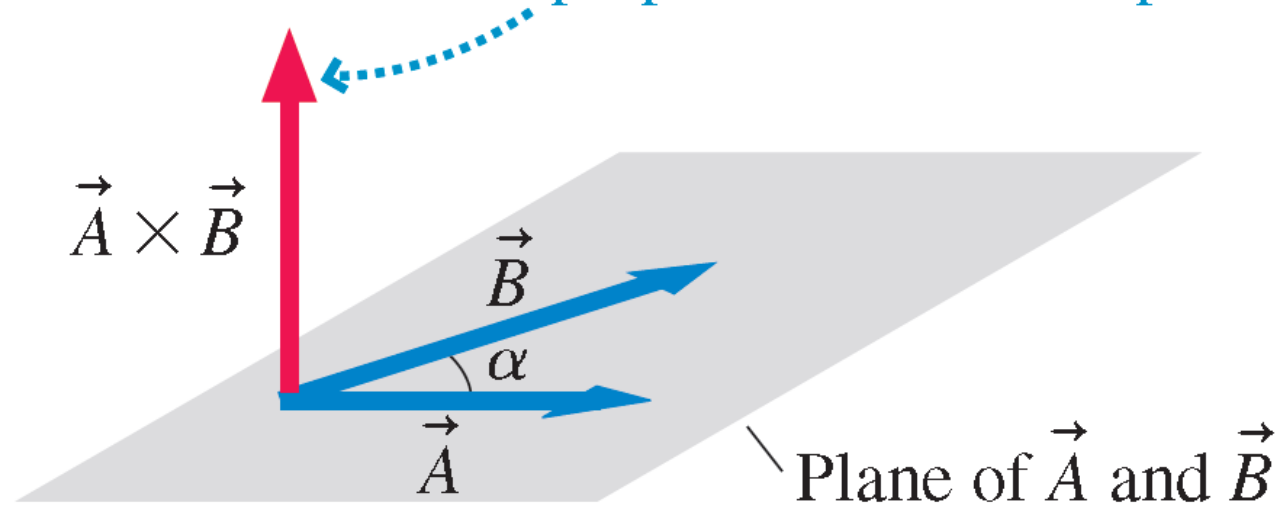

The Right-Hand Rule

The cross product is perpendicular to the plane of \vec{A} and \vec{B} . The right-hand rule for the direction comes in several forms. Try them all to see which works best for you.

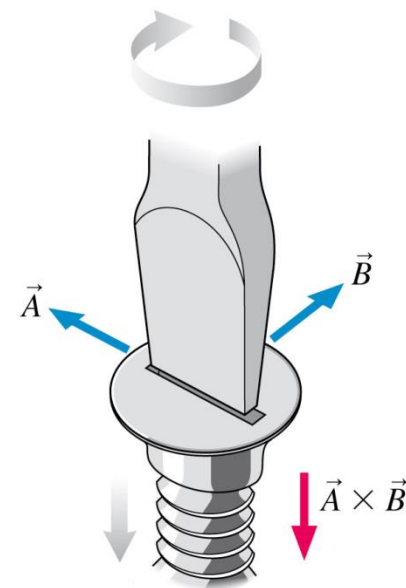
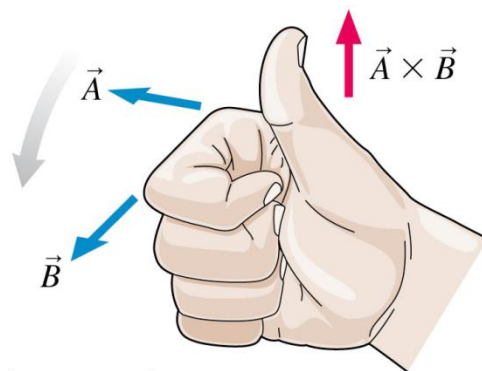
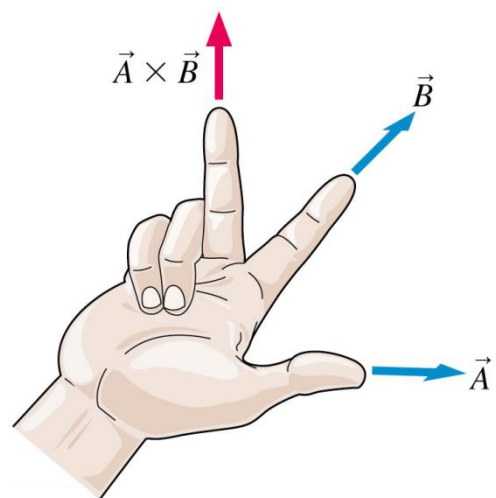

Note that $\vec{B} \times \vec{A} \neq \vec{A} \times \vec{B}$.
Instead, $\vec{B} \times \vec{A} = -\vec{A} \times \vec{B}$.

The Torque Vector

We earlier defined torque $\tau = rF\sin\phi$. r and F are the magnitudes of vectors, so this is really a cross product:

$$\vec{\tau} \equiv \vec{r} \times \vec{F}$$

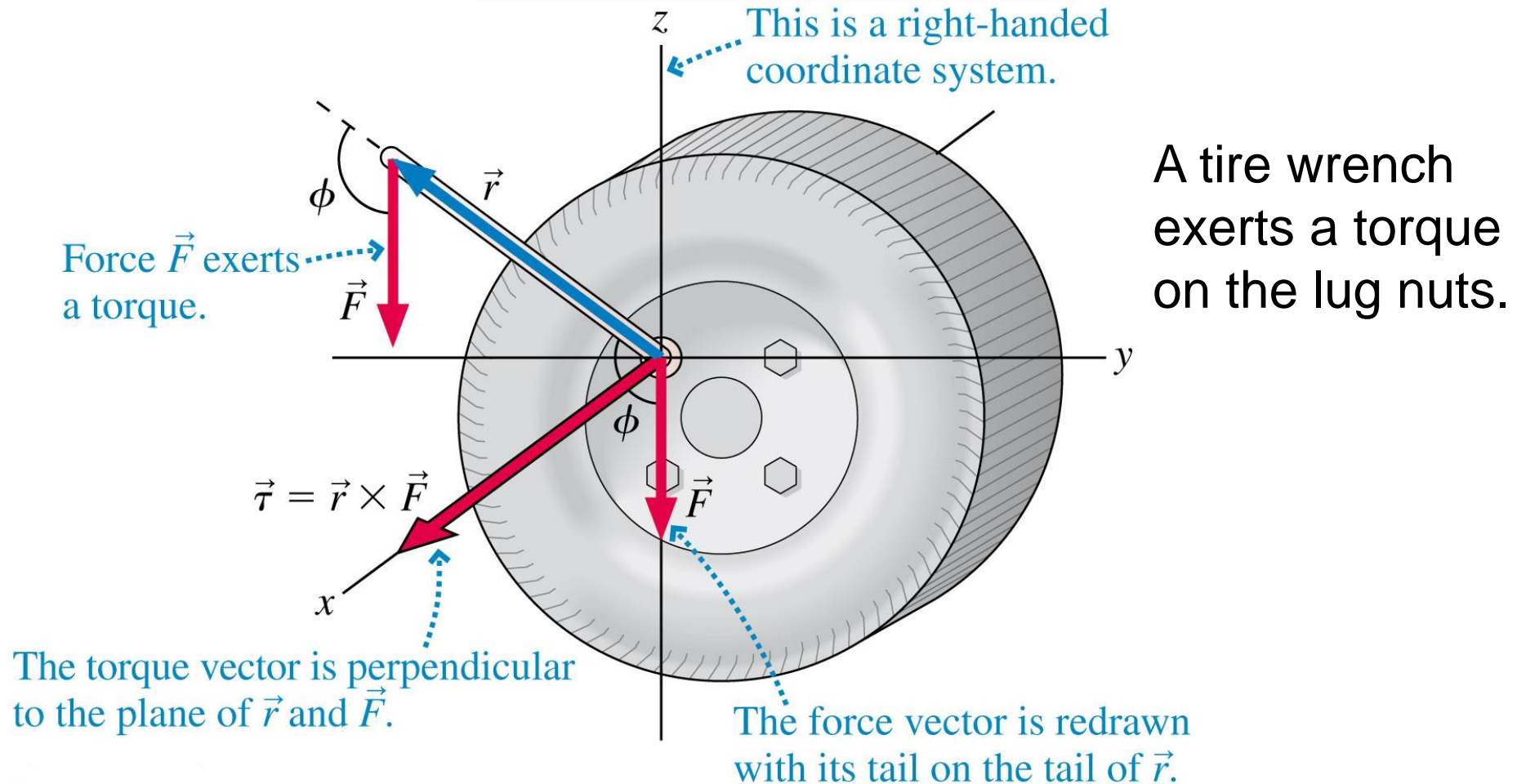

Learning Catalytics

Discussion Question

$$\vec{\tau} \equiv \vec{r} \times \vec{F}$$



“Lefty-loosey, righty-tighty.”

In order to loosen the nuts on a flat tire, a woman attaches the wrench so that it sticks out to the left, and then she presses down on it with her foot.

What is the direction of the torque vector she applies to the nut?

- A. Left
- B. Right
- C. Up
- D. Down
- E. Into the page
- F. Out of the page

Angular Momentum of a Particle

A particle of mass m is moving. The particle's momentum vector makes an angle β with the position vector.

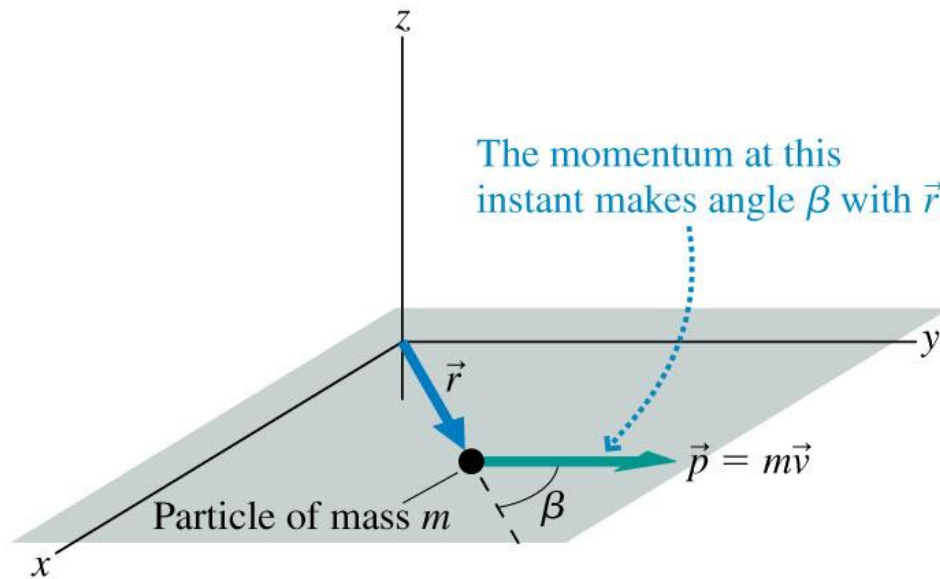

Vectors \vec{r} and \vec{p} define the plane of motion.

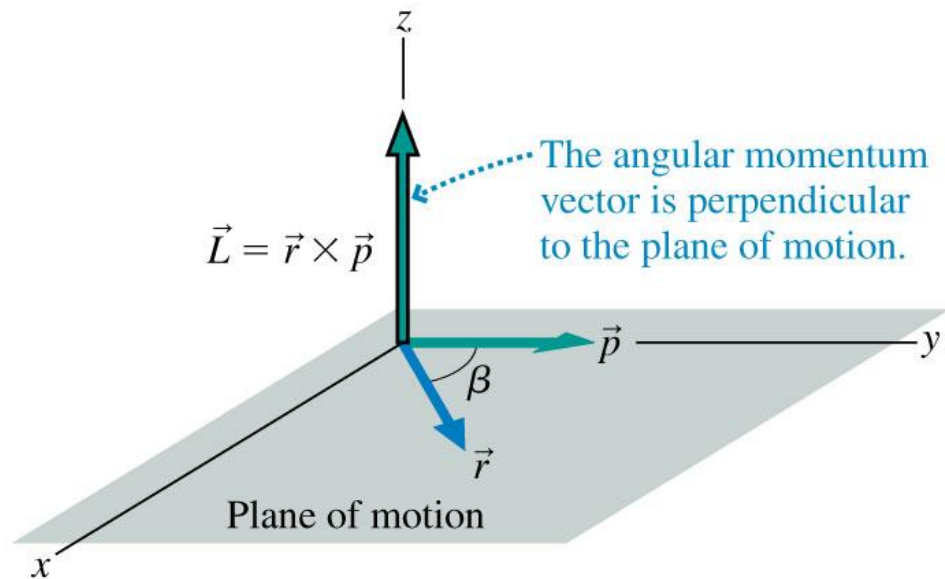

The vector tails are placed together to determine the cross product.

$$\vec{L} \equiv \vec{r} \times \vec{p} = (mrv \sin \beta, \text{ direction of right-hand rule})$$

Angular Momentum of a Particle

Why this definition?

$$\vec{L} \equiv \vec{r} \times \vec{p}$$

If you take the time derivative of \vec{L} and use the definition of the torque vector, you find:

$$\frac{d\vec{L}}{dt} = \vec{\tau}_{\text{net}}$$

Torque causes a particle's angular momentum to change. This is the rotational equivalent of $d\vec{p}/dt = \vec{F}_{\text{net}}$ and is a general statement of Newton's second law for rotation.

Angular Momentum of a Rigid Body

For a rigid body, we can add the angular momenta of all the particles forming the object. If the object rotates

- on a fixed axle, or
- about an axis of symmetry

then it can be shown that

$$\vec{L} = I\vec{\omega} \quad (\text{rotation about a fixed axle or axis of symmetry})$$

And it's still the case that $\frac{d\vec{L}}{dt} = \vec{\tau}_{\text{net}}$.

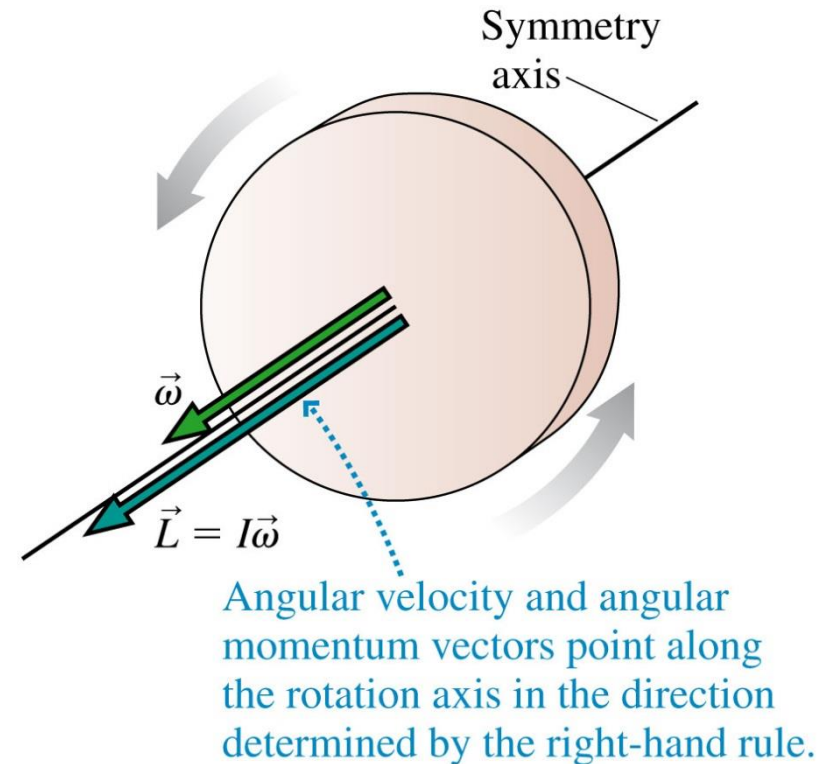

Angular Momentum



- Angular momentum

= rotational inertia \times rotational velocity

$$\vec{L} = I\vec{\omega}$$

- This is analogous to

Linear momentum = mass \times velocity

$$\vec{p} = m\vec{v}$$

Learning Catalytics

Discussion Question

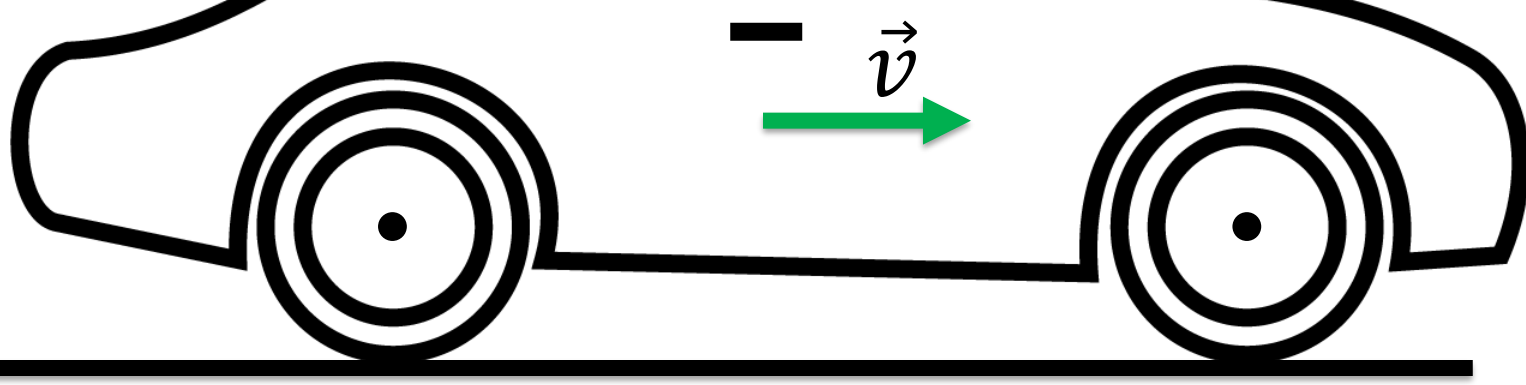

You are driving your car towards the right.

What is the direction of the angular momentum, \vec{L} , of the wheels?

- A. Left
- B. Right
- C. Up
- D. Down
- E. Into the page
- F. Out of the page

Conservation of Angular Momentum

An isolated system that experiences no net torque has

$$\frac{d\vec{L}}{dt} = \vec{\tau}_{\text{net}} = \vec{0}$$

and thus the angular momentum vector \vec{L} is a constant.

Conservation of Angular Momentum

Example:

- When the professor pulls the weights inward, his rotational speed increases!

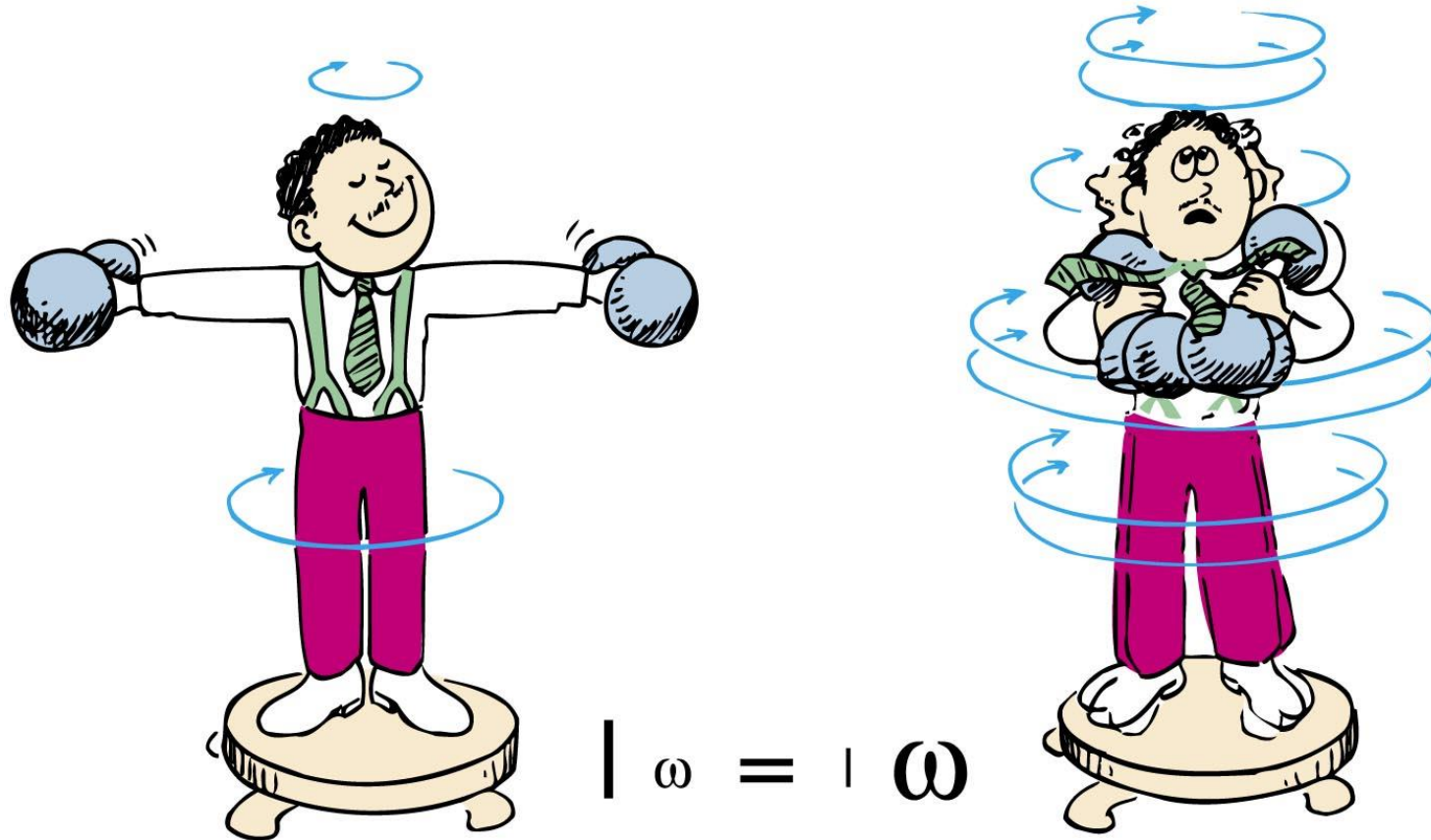

A 20-cm-diameter, 2.0 kg solid disk is rotating at 200 rpm. A 20-cm-diameter, 1.0 kg circular loop is dropped straight down onto the rotating disk. Friction causes the loop to accelerate until it is “riding” on the disk. What is the final angular velocity of the combined system?

Precession of a Gyroscope

- Consider a horizontal gyroscope, with the disk spinning in a vertical plane, that is supported at only one end of its axle, as shown.
- You would expect it to simply fall over—but it doesn't.
- Instead, the axle remains horizontal, parallel to the ground, while the entire gyroscope slowly rotates in a horizontal plane.
- This steady change in the orientation of the rotation axis is called **precession**, and we say that the gyroscope precesses about its point of support.

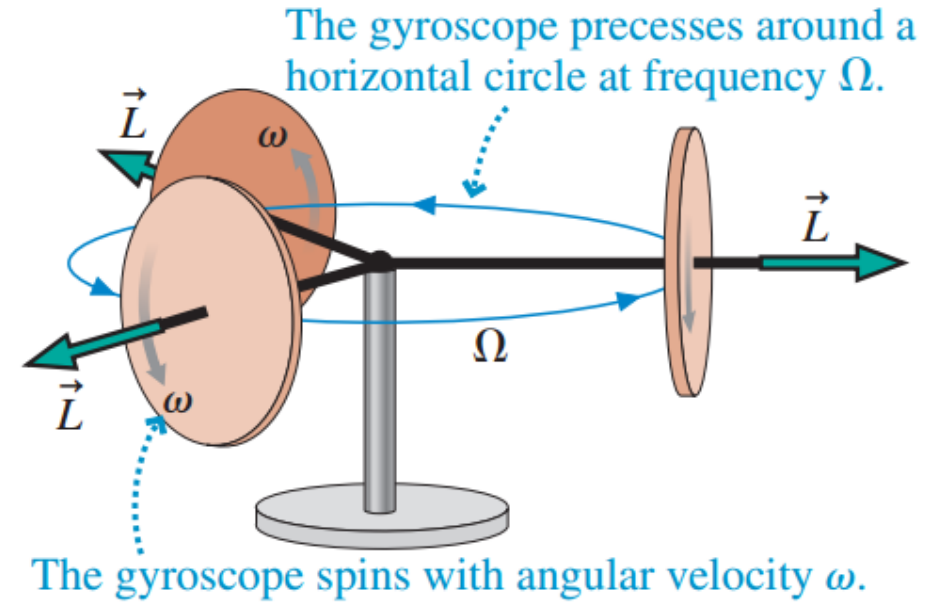

Precession of a Gyroscope

- The precession frequency of a gyroscope, in rad/s, is

$$\Omega = \frac{Mgd}{I\omega}$$

- Here M is the mass of the gyroscope, I is its moment of inertia, and d is the horizontal distance of the center of mass from the support point.
- The angular velocity of the spinning gyroscope is assumed to be much larger than the precession frequency; $\omega \gg \Omega$.

Precession of a Gyroscope

- Wolfson end-of-chapter 11.65
- If you push on the shaft between the arrowhead and the disk, pushing horizontally away from you (ie, into the page), the arrowhead end of the shaft will move
 - a. Away from you (ie into the page)
 - b. Toward you (ie, out of the page)
 - c. Downward
 - d. Upward.

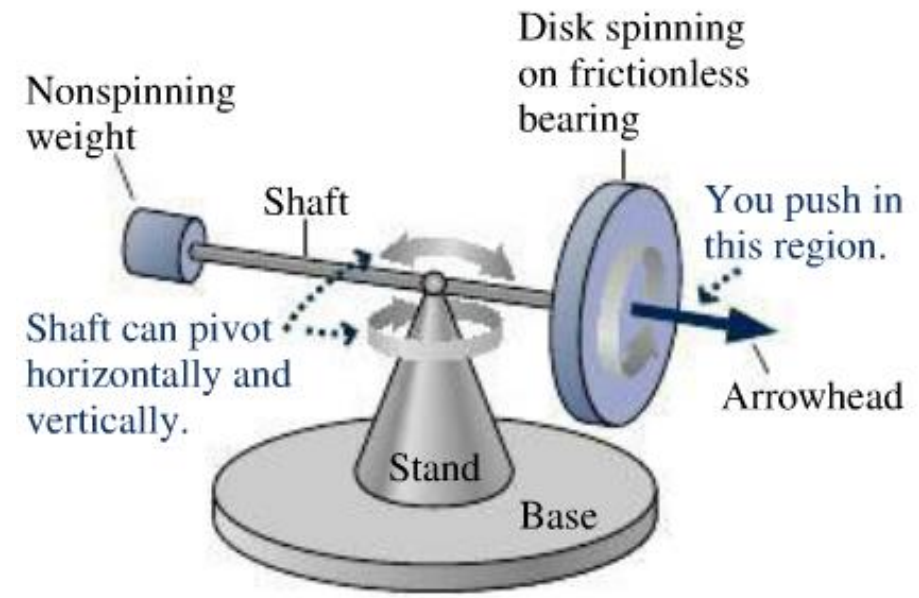

Precession of a Gyroscope

- Wolfson end-of-chapter 11.66
- If you push on the shaft between the arrowhead and the disk, pushing directly upward on the bottom of the shaft, the arrowhead end of the shaft will move
 - a. Away from you (ie into the page)
 - b. Toward you (ie, out of the page)
 - c. Downward
 - d. Upward.

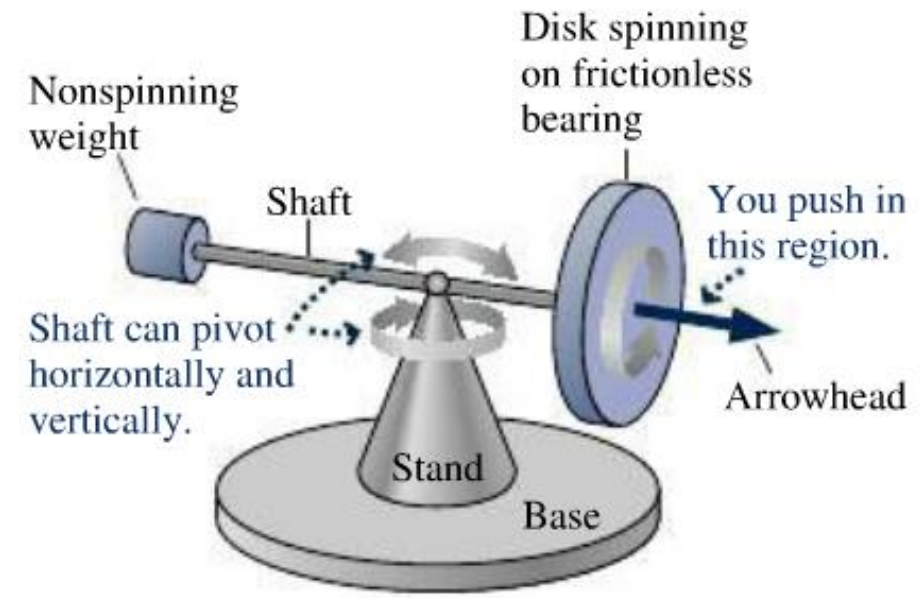

Precession of a Gyroscope

- Wolfson end-of-chapter 11.67
- If an additional weight is hung on the left end of the shaft, the arrowhead will
 - a. pivot upward until the weighted end of the shaft it's the base.
 - b. pivot downward until the arrowhead hits the base.
 - c. precess counterclockwise when viewed from above.
 - d. precess clockwise when viewed from above.

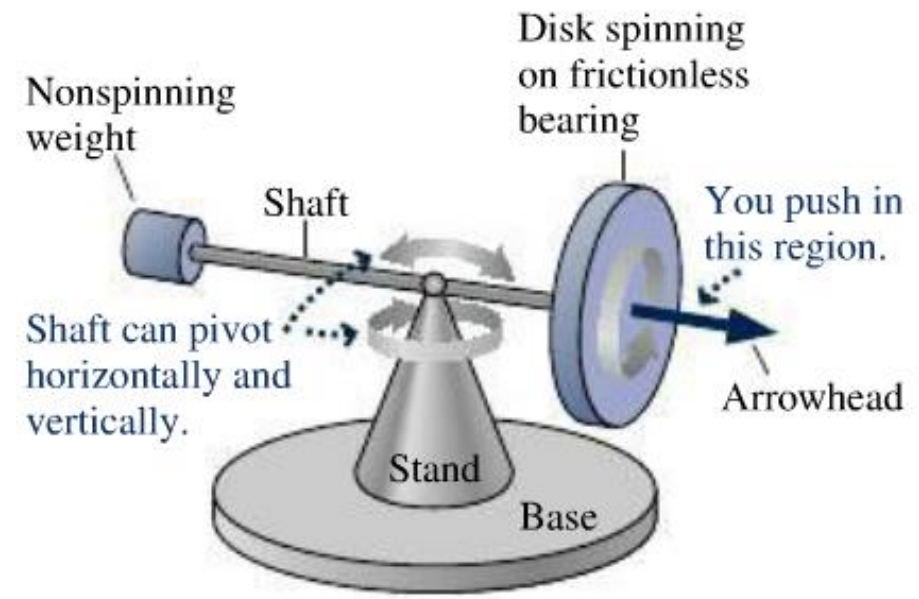

Nuclear Magnetic Resonance

- A proton in the nucleus of an atom is like a little spinning top.
- When placed in a strong static magnetic field, the magnetic force produces a torque on the proton, which causes it to precess.
- The precession frequency is in the radio-frequency range, which allows the proton to absorb and re-emit radio-waves.
- This allows doctors to image inside the human body using completely harmless radio waves.

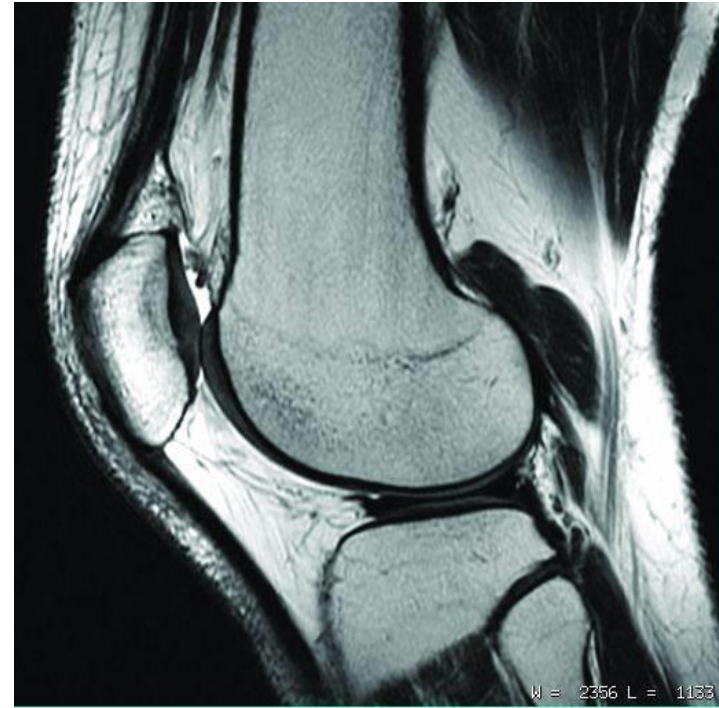

Before Class 19 on Wednesday

- Please read chapter 12 on Static Equilibrium, or at least watch the Preclass 19 Video.



- Problem Set 9 on Chapters 10 and 11 is due Monday at 11:59pm.
- Something to think about over the weekend: The supports to the diving board provide a vertical force on the board so the girl will not fall. What are the directions of the force on the board at point 1 and point 2: up or down? Why?

