

Photoelectric Effect

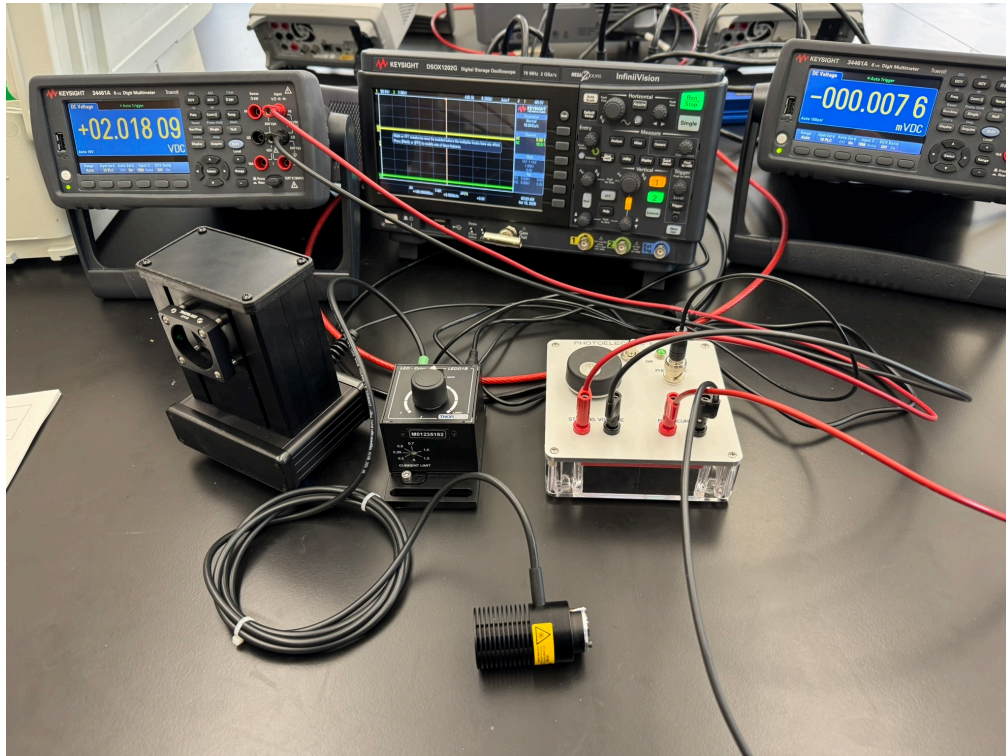

Revisions

025 C. Lee

2023 T. Vahabi, C. Lee

2016 R. M. Serbanescu

current revision: ca33e6c

date: March 28, 2026

© 2016-2023 University of Toronto

This work is licensed under the Creative Commons Attribution-NonCommercial-ShareAlike 4.0 Unported License (<http://creativecommons.org/licenses/by-nc-sa/4.0/>)





This experiment uses an ultraviolet LED with emission in the UV-A band (380nm-400nm). This LED produces potentially harmful UV light. Limit the time you are exposed to this UV light and switch it off after use.

Introduction

Discovery

In 1899, J.J. Thomson discovered that when a metal target is irradiated by ultraviolet light it emits negative charges. These charges were found to have the same charge/mass ratio as the electron. This effect was named the photoelectric effect, and the emitted electrons called photoelectrons. To explain the effect, a mechanism was proposed by which the energy in the oscillating electric field of the UV light was continuously transferred to the bound electrons. Electrons that had absorbed more than a certain amount of energy characteristic of the metal E_o (called the work function), would be ejected with a kinetic energy (E_k) equal to the difference between the total energy absorbed by the electron (E_e) and the work function (E_o):

$$E_k = E_e - E_o \quad (1)$$

This explanation was based on Maxwell's very successful theory of light. In Maxwell's theory, the energy present in electromagnetic fields is distributed continuously throughout the spatial extent of the field and is proportional to intensity of the field (the square of the field). One corollary of this explanation was that if metal was irradiated by very dim light, it would take a while for the electrons to absorb energy equal to E_o and therefore the discharge would be delayed slightly.

First Study

Shortly after the discovery of this effect, Philip Lenard performed the first systematic study of the photoelectric effect. He used a glass vacuum chamber with two electrodes configured as an anode and cathode, and a window to allow light to shine on the cathode surface (see Figure 1):

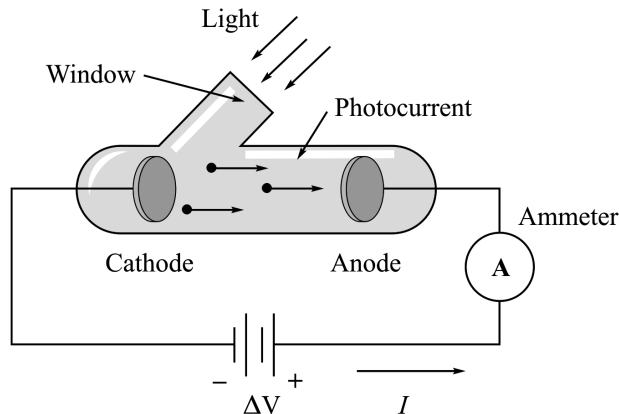

Figure 1: Lenard's experiment

By using an ammeter, Lenard was able to measure the photocurrent as a function of the intensity and frequency of the light. By varying the potential difference (ΔV) between cathode and anode, Lenard could measure the kinetic energy of the photoelectrons ejected from the cathode. He made a number of observations which appeared to be at odds with the originally proposed theory:

- Current is proportional to the intensity of the irradiating light.
- Current appears without delay regardless of the dimness of the irradiating light source.
- Photoelectrons are emitted only if the frequency of the irradiating light source exceeds a threshold frequency f_o . The value of f_o appears to be characteristic of the type of cathode metal.
- If the potential difference ΔV is made negative (electrons are decelerated as they approach the anode) the current decreases until it becomes zero (at $\Delta V = V_{stop}$). V_{stop} is called *stopping potential* and it is independent of the intensity of the irradiating light source but dependent on the frequency of the source. An electron with kinetic energy E_k ejected by the cathode will be prevented from reaching the anode by a stopping voltage:

$$V_{stop} = \frac{E_k}{e} \quad (2)$$

Einstein's interpretation

In his famous 1905 paper, Einstein noted that:

The usual conception that the energy of light is continuously distributed over the space through which it propagates encounters very serious difficulties when one attempts to explain the photoelectric effect...

$$E = hf \quad (3)$$

where $h = 6.63 \times 10^{-34}$ J·s is Planck's constant and f is the frequency of light. In the presence of quantized electromagnetic radiation an electron can escape from a metal if $hf \geq E_o$ where

any excess energy becomes the kinetic energy of the ejected electron. If we assume the intensity of the light is not high enough for electrons to have a very high chance of absorbing more than a single photon then we can combine equations 1, 2 and 3 to obtain Einstein's equation for the photoelectric effect:

$$eV_{stop} = hf - E_o \quad (4)$$

Or in terms of frequency:

$$V_{stop} = \frac{h}{e}(f - f_o) \quad (5)$$

It is clear from equation 5 that a graph of V_{stop} vs. f provides a way to measure Planck's constant h and the cutoff (or threshold) frequency f_o . Light below the cutoff frequency will have a negative stopping voltage - physically this means the light is unable to excite electrons in the cathode.

Experimental Notes

The light source used in the apparatus consists of several interchangeable light emitting diodes (LEDs). Figure 2 shows the experimental arrangement.

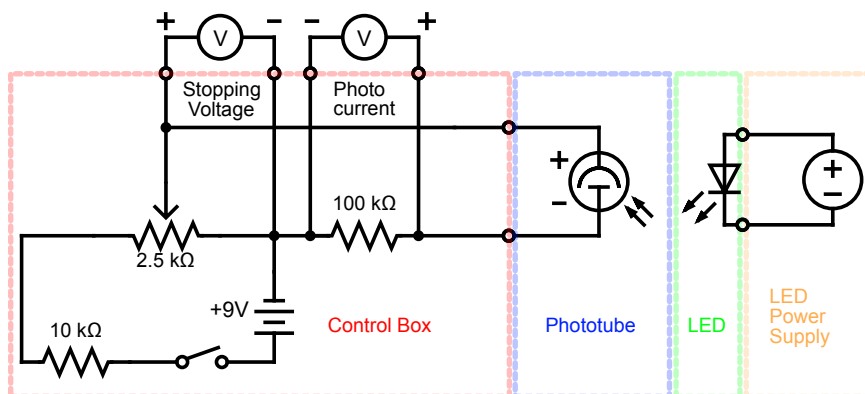

Figure 2: The experimental circuit

The LEDs should be mounted on the power supply box so that light enters the phototube and is incident on the cathode. There are 8 diodes emitting from 395 nm (UV) to 940 nm (IR), and each one can be driven with a constant voltage or by the function generator in the oscilloscope. The spectrum for each LED is plotted in figure X and the spectrum raw data provided in CSV files. For each LED you should determine a wavelength and a bandwidth. The central wavelength is the wavelength at which the LED emits the most light, and it is usually given in the manufacturer's technical specification, but it might not be the most relevant value for this experiment. The bandwidth is the range of wavelengths around the central wavelength where the LED emits light with significant intensity.

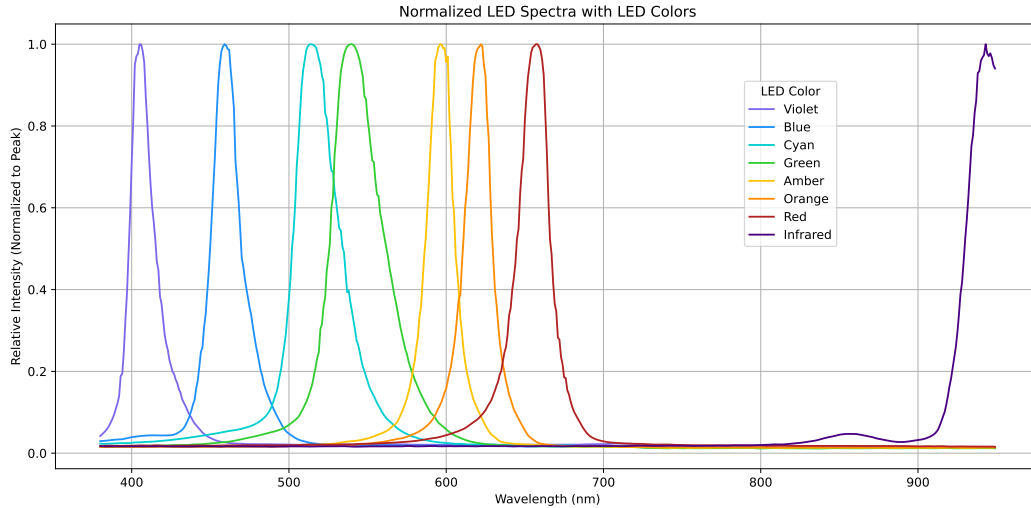

Figure 3: The spectrum of the LEDs used in the experiment. The approximate of each LED is used to color each line and the model number in parentheses is written on the back of each LED.

The Experiment

The experiment is performed using each LED as a monochromatic light source. For the light source you will connect the LED to the Thorlabs LED driver. The driver has three modes

- **CW**: The LED is driven by a constant voltage. The LED brightness is controlled by the control knob.
- **TRIG**: The LED brightness is controlled by the knob, but an external signal is used to turn the LED on and off. The external signal is connected to the MOD IN port of the LED driver.
- **MOD**: The LED is controlled completely by a external voltage. 0V corresponds to off and 5V represents the maximum current. Any modulation signal can be used.¹

On the detector side, the phototube is connected to a controller box. The phototube is a vacuum tube with a cathode and an anode. Current generated in the phototube is converted to a voltage across a 100-k Ω resistor inside the controller box. A built-in multi-turn potentiometer is used to provide a stopping voltage to stop the current flowing, and ports for multimeters to measure the voltage output by the potentiometer and the voltage generated by the photocurrent.

Exercise 1

Connect an LED into the driver and turn it on. Align the diode head with the phototube window. Set up the two multimeters as voltmeters (remember that photocurrent is

¹<https://www.thorlabs.com/thorproduct.cfm?partnumber=LEDD1B>

measured as a potential drop across the $100\text{ k}\Omega$ resistor). With the bias voltage enabled, measure the stopping voltage (V_{stop}) needed to reduce the photocurrent to zero. Watch the photocurrent as you adjust the potentiometer - it will not vary linearly with the stopping voltage. You should repeat this test a few times and note the spread of stopping voltage values that produce zero photocurrent. Record the stopping voltage (at zero photocurrent) and photocurrent (at zero stopping voltage) for each LED. Repeat this for each of the 8 LEDs provided.

The uncertainty calculation is not trivial in the experiment. The voltmeters are highly accurate, but your stopping voltage will likely have a larger spread in values than the reading error of the voltmeter. The LEDs are non-linear devices and brighter LEDs will have more light output away from the central peak. You can estimate the uncertainty in the stopping voltage by taking the standard deviation of the stopping voltages you measured for each LED. You can estimate the uncertainty in the LED by calculating the bandwidth of each LED.

Determine the following quantities:

1. Planck's constant h ,
2. The work function E_o ,
3. The cutoff (threshold) frequency f_o .

Exercise 2

In Einstein's explanation of the photoelectric effect, the stopping voltage is proportional to the frequency of the light source. The photocurrent is proportional to the intensity of the light source. In this exercise you will test these two relationships.

Using one LED, measure the stopping voltage and photocurrent as a function of the LED intensity. The intensity can be controlled by the knob on the LED driver in CW mode. You can also use the MOD modes and the oscilloscope/wave generator as a DC supply to provide known voltages to the LED driver.

Plot the photocurrent against intensity, and the stopping voltage against intensity. Fit a suitable model to each dataset to determine if each is constant or proportional to the intensity.

References and Recommended Readings

- W. P. Garver: The Photoelectric effect Using LEDs as Light Sources, The Physics Teacher 44 (p.272-275), 2006
- Einstein's Proposal of the Photon Concept - a translation of the *Annalen der Physik* paper of 1905 in: A. B. Arons and M. B. Peppard. Am. J. Phys. 33, 5 (1965).